

YOONIT

The Mini Cargobike — Manual

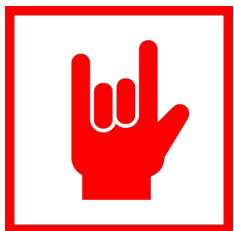

Hello



We are happy that you have chosen a YOONIT mini cargo bike!

The YOONIT is an ultra-compact and light cargo bike. It adapts to your needs with different transport solutions – for children, shopping, beverage crates, cardboard boxes, commercial use and much more.

The YOONIT is fast, agile and with a length of 178 cm it is shorter than a normal bike. It fits in elevators, can be taken on the train and can be easily stowed in the bicycle cellar.

YOONIT — mini bike, max options.

Contents

These instructions will help you to find out everything you need to know about your YOONIT – from commissioning to maintenance.

To ensure that you enjoy driving and that you are safe on your YOONIT, read the instructions completely before your first ride.

Hello	2
Component description YOONIT Classic	4
Component description YOONIT Electric	5
Dimensions	6
General information	7
Legal requirements	8
Intended Use	9
Unboxing	10
Before your first ride	12
Before every trip	15
Ergonomics and seating position	16
Cockpit elevation	17
Quick release	18
Safe loading	19
Attachment of the carriers	20
Smart Carrier	21
Job Carrier	23
Family Carrier	25
Child Seat	28
Child Seat 2	31
Cover	34
Canopy	35
Dog Seat	39
Base Carrier	42
Euro Carrier	43
Rack	48

Weber adaptor	50
Steering	51
Brakes	52
Gear shift	54
Gates belt drive	55
Wheels and tires	56
Lighting system	57
Double kickstand	58
Frame lock	59
Bottle holder	60
Frame	61
E-bike system	62
Battery pack	64
Care and cleaning	67
Inspection	68
Transport	69
Tightening torques for screws	70
Warranty and guarantee	71
After the last trip	72
Imprint	73

Component description

YOONIT Classic



1 Wheels

Front rim
Alienation Black Sheep (27 x 305, 36L)
Rear rim
Alienation Black Sheep (27 x 355, 36L)
Front tire
Salt Tracer Cargo 55-305
Rear tire
Salt Tracer Cargo 55-355
Front tube
AV16 47-64 / 305 mm
Rear tube
AV16 47-64 / 355 mm
Front hub
Shimano Hub dynamo DH-3D37
Front fender
SKS
Rear Fender
SKS with integrated light

2 Drive

Crank
Miranda Delta, 170 mm
Pedals
Platform pedals
Gear shift
Shimano Alfine 8-Gear
Belt (optional)
Gates Carbon Drive

3 Braking system

Front brakes
Magura CT hydraulic disc brake
(2 pistons)
Rear brakes
Magura CT hydraulic disc brake
(2 pistons)
Front disc brake rotor
Magura Storm CL ø180 mm
Rear disc brake rotor
Magura Storm CL ø180 mm

4 Seating

Saddle
Selle Royal Lookin 3D
Seat post
ergotec VIPER ø30.9 mm, L 400 mm
Seat clamp
Shimano PRO ø34.9 mm

5 Cockpit

Handlebar
ergotec Ladytown
Stem
ergotec SHARK 110 mm
Grips
ergotec 130/130 mm

6 Frame

Frame
CrMo steel
Fork
16", CrMo steel
Kickstand
Ursus Jumbo 80
Steering
Tie rod steering
with steering damper
Frame lock
ABUS ProShield 5950

7 Lighting system

Front light
Busch & Müller Lumotec DOPP
Taillight
Busch & Müller XelTec
Rear reflector
Busch & Müller Mini-Z



Component description

YOONIT Electric



1 Wheels

Front rim
Alienation Black Sheep (27 x 305, 36L)
Rear rim
Alienation Black Sheep (27 x 355, 36L)
Front tire
Salt Tracer Cargo 55-305
Rear tire
Salt Tracer Cargo 55-355
Front tube
AV16 47-64 / 305 mm
Rear tube
AV16 47-64 / 355 mm
Front hub
Shimano Deore
Front fender
SKS
Rear Fender
SKS with integrated light

2 Drive

Drive Unit
Shimano EP6 (85Nm)
Battery pack
BT-BT-EN605 (504 Wh)
Crank
Shimano STEPS, 170 mm
Pedals
Platform pedals
Gear shift
Shimano NEXUS 5 Di2
Belt (optional)
Gates Carbon Drive

3 Braking system

Front brakes
Magura CT hydraulic disc brake
(2 pistons)
Rear brakes
Magura CT hydraulic disc brake
(4 pistons)
Front disc brake rotor
Magura Storm CL ø180 mm
Rear disc brake rotor
Magura Storm CL ø180 mm

4 Seating

Saddle
Selle Royal Lookin 3D
Seat post
ergotec VIPER ø30.9 mm, L 400 mm
Seat clamp
Shimano PRO ø34.9 mm

5 Cockpit

Handlebar
ergotec Ladytown
Stem
ergotec SHARK 110 mm
Grips
ergotec 130/130 mm

6 Frame

Frame
CrMo steel
Fork
16", CrMo steel
Kickstand
ergotec DOUBLE FLEX 3
Steering
Tie rod steering
with steering damper
Frame lock
ABUS ProShield 5955

7 Lighting system

Front light
Busch & Müller Lumotec DOPP
Taillight
Busch & Müller XelTec
Rear reflector
Busch & Müller Mini-Z



Dimensions

Smart Carrier

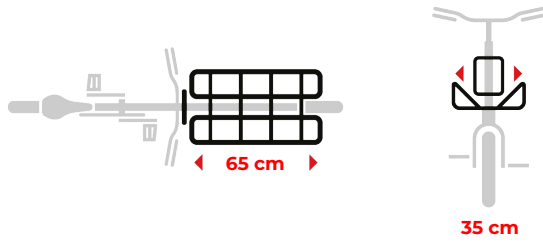

Job Carrier

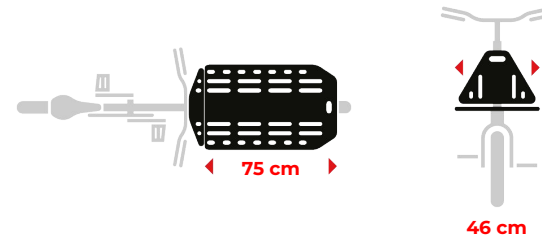

Family Carrier

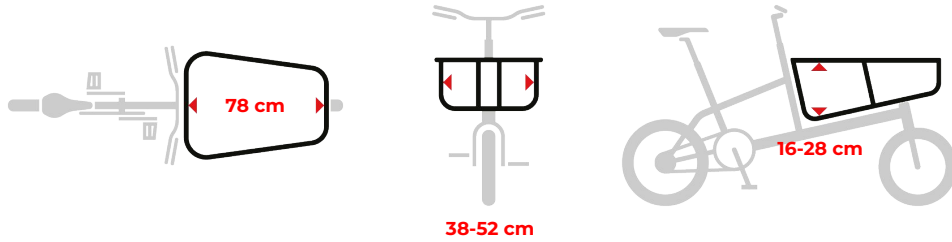

Base Carrier

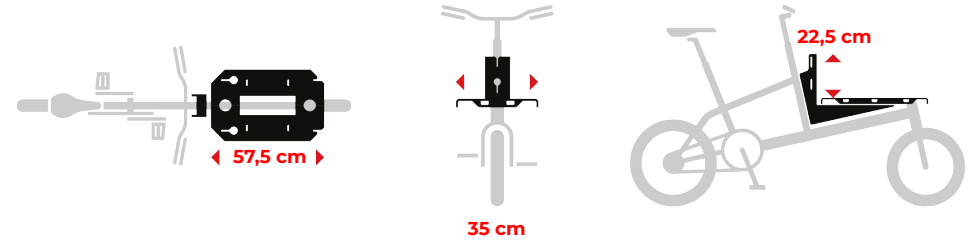

Euro Carrier

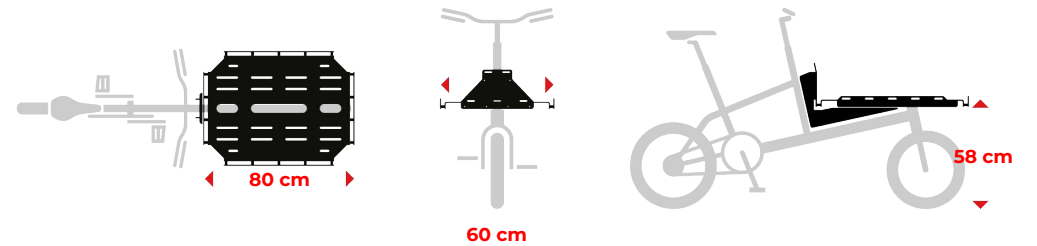

General information

In addition to explanatory texts, these instructions will also accompany you with symbols that indicate helpful tips, special features or dangers. This can concern the assembly of your YOONIT or the professional handling of it.

You will encounter the following signs:



Tips and hints

This symbol draws your attention to important information and tips that offer additional help or explain the context.



Control check

We have created lists with which you can process operations.



Attention

This symbol warns you of wrongdoing that could endanger your YOONIT and the environment.



E-Bike

hereinafter referred to as **YOONIT Electric**



Danger

Attention! Here we point out risks that could be dangerous for your health and that of those around you. Please strictly adhere to our precautionary measures, otherwise serious or fatal injuries to the driver or occupants may result.



without electrical assistance

hereinafter referred to as **YOONIT Classic**



Link to external operating instructions

Legal requirements

In order to take part in public traffic, your YOONIT must meet the requirements of the traffic regulations of the country in which you want to drive. The YOONIT is legally equivalent to a bicycle and its operation is therefore subject to the same regulations. When participating in traffic, the same rules apply to cyclists as to drivers of a motor vehicle.

In Germany, the relevant conditions are defined by the Road Traffic Licensing Regulations (StVZO) and the Road Traffic Regulations (STVO). Among other things, they define the requirements for the braking and lighting system and stipulate the use of a brightly sounding bell. A bicycle must have two brakes that work independently of one another, one on the front and one on the rear.

All cyclists are obliged to keep their bike in a roadworthy condition and to maintain it or have it serviced accordingly. In Germany there is no obligation to wear a helmet. However, we recommend that you wear one for your own safety.

Before driving in another country, please find out about the legal requirements there.

Provisions for the Bicycle Ordinance for Austria are set out in the 146th Ordinance: Bicycle Ordinance of the Federal Law Gazette for the Republic of Austria. When using your bike in Switzerland, please inform yourself about the valid regulations in the "Ordinance 741.41 on the technical requirements for road vehicles" (VTS) in Articles 213 to 218.

Intended use

Your YOONIT was designed and constructed for use on roads or paved paths. The YOONIT is intended for urban mobility and for participation in road traffic. The wheels should be in constant contact with the ground. Do not take your hands off the handlebars while riding. You should not ride wheelies, jump, descend stairs or perform similar maneuvers with your YOONIT. Attention! It is imperative to avoid transporting people other than intended, overloading the YOONIT or incorrectly assembling or repairing it. You run the risk of personal injury and property damage that can endanger your health and life. The guarantee of your YOONIT is void in these cases.



Please pay attention to the permissible total payload, consisting of the weight of the rider + load.

	Classic	Electric
Curb weight: YOONIT (incl. battery)	21 kg	27 kg
Curb weight: Smart Carrier	2 kg	
Curb weight: Job Carrier	5 kg	
Curb weight: Family Carrier	5 kg	
Permitted driver's weight	100 kg	
Permissible load capacity	80 kg	
Permissible total payload	155 kg	

Unboxing

Your YOONIT was set up with great care in Germany and will largely be handed over to you pre-assembled. Nevertheless, check all screw connections before you take your first ride with the Mini Cargobike. More information and torque specifications can be found on [page 67](#).

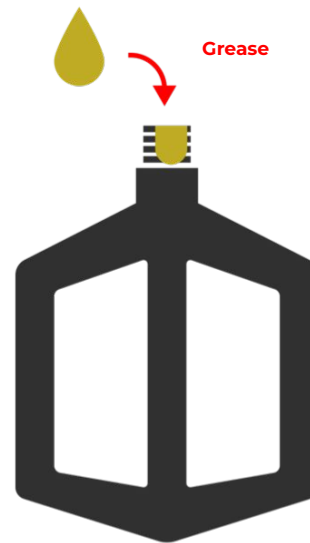

Step 1 Mount the pedals

Grease the threads of the pedals before attaching them. Only in this way can they be removed again after years of use.

You can recognize the left and right pedals by the embossed letters "L" and "R". Screw them into the threads as shown. The left pedal counterclockwise, the right pedal clockwise. Tighten to 35-40 Nm with a torque wrench.

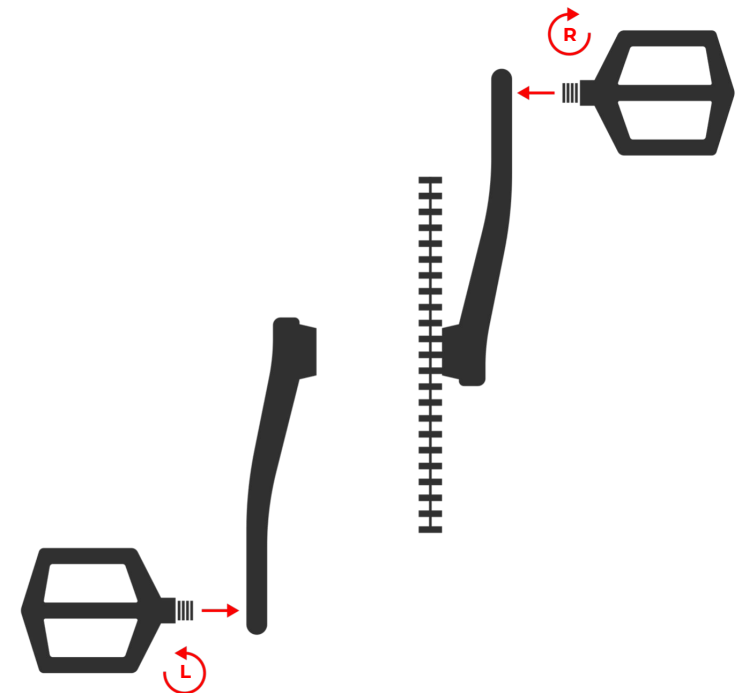

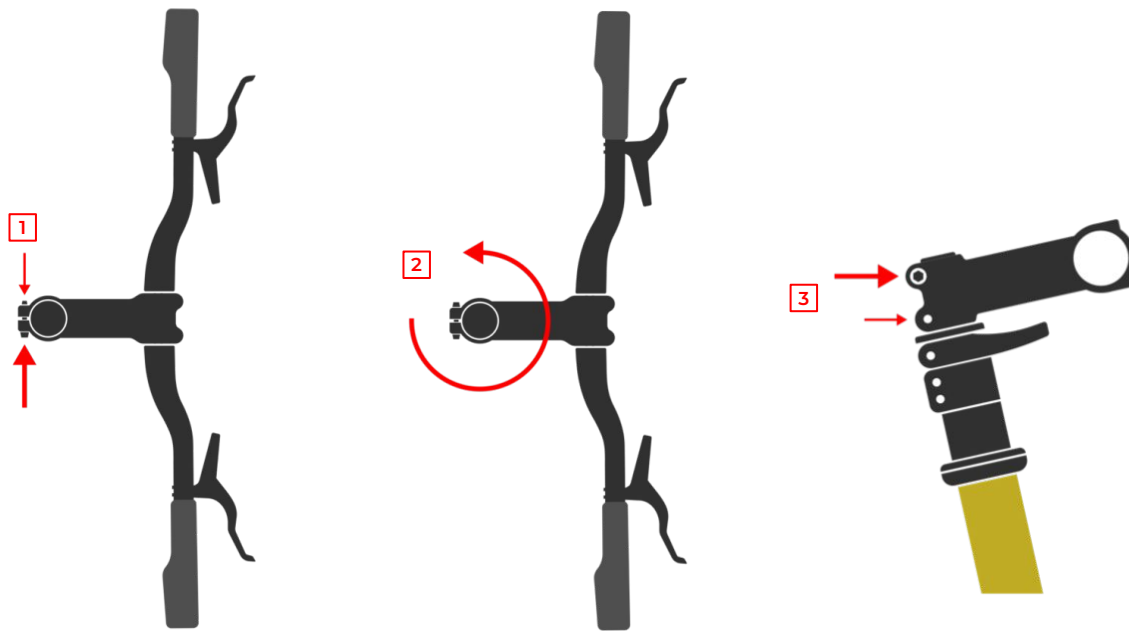

Step 2 Aligning the handlebar

Loosen the two screw connections on the stem [1]. Put the handlebar in a straight position [2]. You can also take the front wheel between your legs and make sure that it is parallel to the stem.

If the handlebar is aligned correctly, screw the fastening screws alternately to [3]. Pay attention to the correct torque of 6–8 Nm.



Only use the screws described to align the handlebars. Do not loosen the quick release or the plug on the stem adapter.



Step 3 Attaching the quick releases for the Adapt system

Take the three enclosed quick releases and guide the axles through the three openings [4] provided in the adapter system. Make sure that the quick release levers are placed on the right in the direction of travel.

Screw the preload screw only a short distance on the axle, so that you have enough space when you attach your carrier.

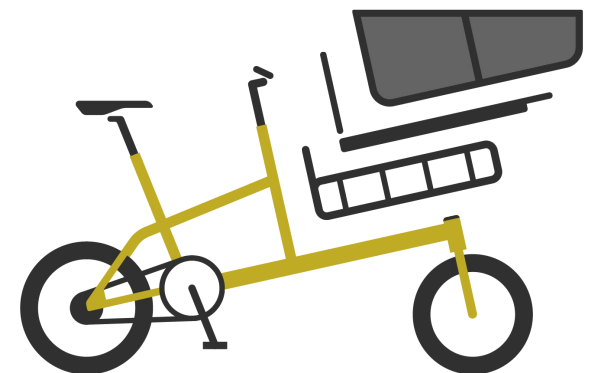

Step 4 Fastening your carrier

Now you can fasten your carrier. You can find out exactly how this works on page 20.

Before your first ride

Before your first ride, read through all the warnings and notes that we have compiled for you in these instructions. If you have any questions after reading this, please do not hesitate to contact us at hello@yoonitbikes.com.

Driving in traffic requires a high level of concentration and fitness. Slowly test yourself on the properties of your YOONIT in a lonely place so that you feel safe while driving and braking.

We have summarized the most important steps that you should always observe before you can set off with your YOONIT.

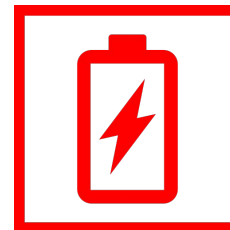

Step 1 recharging the battery

When you receive your YOONIT Electric, the battery is not charged. Charge it fully. You can remove it from the YOONIT Electric or leave it attached to the bike.

An LED panel on the battery shows you that it is charging. You can find details about the battery in the instructions supplied with the drive system.



Step 2 Control check

- Are the handlebars and saddle adjusted for you?
- Can the steering move without play?
- Are you familiar with the characteristics of your platform pedals? There may be a risk of slipping when wet.
- Are the wheels properly seated in the fork and frame?
- Is the tire pressure suitable for your journey with or without a load?
- The front and rear wheels must be inflated to a pressure of 2.00 - 5.00 bar (30 - 70 psi).
- Are you familiar with the functions and operation of the add-on parts?
- Which brake lever actuates the brake of the front wheel, which one of the rear wheel? Make a note of the assignment of the brake levers.
- Are the brakes working properly and are the brake levers within easy reach?
- Have you checked that all fastening screws and nuts are correctly seated?



If one of these points is not met, please have your YOONIT checked by one of our service partners before your first trip.

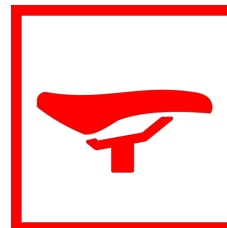

Step 3 Fitting

An ergonomically correct sitting position is important for efficient driving with symptom-free movement sequences. On page 16 you will find information on the optimal adjustment of the handlebars and saddle.

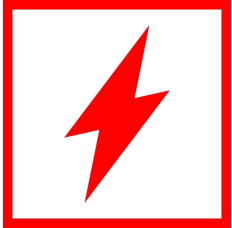

Step 4 Switch on your STEPS system

Is the battery charged? Then the Shimano STEPS system can be switched on. The display informs you about the battery level, your speed and the selected support level.

- Press the button on the battery to start the system.
- Choose the level of support you want.
- In the menu you can switch the bike's lights on and off. We recommend that you always drive with the lights on. This increases your visibility in traffic.



To charge the battery, you can remove it from the YOONIT Electric or leave it attached to the bike.



Before every trip

Impellers

Check the condition of the tires and their air pressure. The wheels must run smoothly.

Lighting

Are the front and rear lights working properly? The front light should be set correctly so that other road users are not dazzled.

Brakes

When you pull both brake levers, you should feel a distinct pressure point. The brakes are not properly adjusted if you can pull them all the way to the handle.

Payload

Make sure to load your YOONIT evenly and that your load is always fixed. No safety-relevant parts may be disturbed or covered in their function during transport. Driving stability can suffer from incorrect loading. Driving and braking behavior can change with a heavy load.

total weight

The permitted total weight must not be exceeded. Please refer to the table on page 50, which shows the total weight for your YOONIT.

battery pack

Make sure that the battery is sufficiently charged before every journey. Before driving, check that the battery is firmly seated in the holder, it should be audibly locked into the holder. It is also important to check the seat again after the journey.

Quick release and screw connections

Before every ride, check that all quick releases and screw connections are firmly tightened. The quick releases on the front wheel, on the Adapt System of the carrier, the cockpit riser and the seat post must be tightened before you set off.



When you've worked through the checklist and followed everything, you're good to go. If there is a problem with one or more components, please contact your service partner or contact our support team at hello@yoonitbikes.com.



As soon as you step down the pedal of your YOONIT Electric, the motor switches on. You can adjust in advance how much it supports you. Once you have reached the top speed of 25 km/h, the support switches off. The drive switches on again automatically as soon as the speed has fallen below 25 km/h and you start pedaling again.

Ergonomics and seating position

Before using your YOONIT for the first time, you should adjust the seating position to your height. A seat position that is adjusted to you is essential for safe, comfortable and efficient driving with symptom-free movement processes. The saddle offers adjustment options in terms of height, horizontal alignment and inclination. Handlebars and stem can be adjusted in height and orientation.

Saddle height

Estimate the right height of the saddle for you and fix it with the quick release. Sit on your YOONIT. Avoid tilting, you can also have someone hold you. Now place your heel on the turned down pedal. If your leg is straight in this position, the saddle is at the correct height. If you now put the pedal and leg in the right position to start driving, the leg should be slightly angled.

If your foot is at its widest point above the pedal axis, your foot is correctly positioned.

The saddle height depends on the body size of the rider. Driving the YOONIT must be possible without impairing driving safety or health. Only pull out the seat post so far that the seat post clamp is still securely clamped.



Make sure that you can safely reach the ground with your feet while sitting on the saddle. Otherwise, there is a risk of tipping over with a heavy load.



Attention! The seat post must never be pulled out of the seat tube further than the embossed mark. If no marking is visible, at least 7.5 cm of the seat post must remain in the seat tube.

Saddle inclination

Before starting your journey, you should test whether the saddle and seat post are securely attached. Grab the front and back of the saddle and try to turn it. It shouldn't be able to move.

Once the saddle height has been adjusted, its incline must also be adjusted. You can adjust the saddle when the saddle clamp screws on the seat post are open. The position of the saddle is correct when it is level.

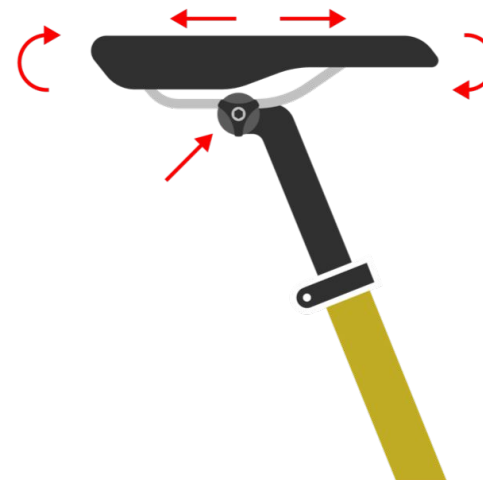

Cockpit elevation

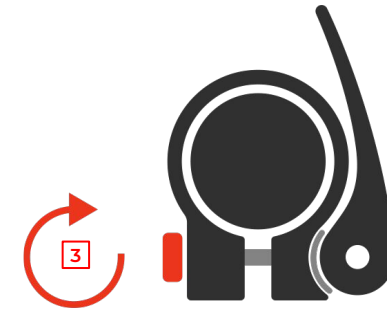
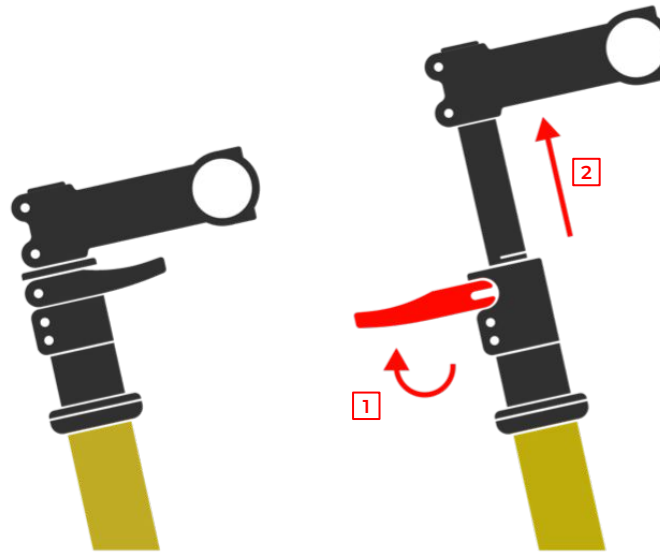

Your YOONIT is equipped with a height adjustment system for the handlebar. With the help of the quick release mechanism, the handlebars can be easily adjusted in height without tools.

Height adjustment

To adjust the height of your cockpit, proceed as follows: Open **the quick release lever [1]**. By pulling up or pushing down the stem adapter, the height of the grip position can be adjusted to your individual needs. Pay attention to **the maximum extension length [2]**. Then close the quick release lever again. Check the preload of the quick release lever. If there is no longer any preload, turn **the adjusting screw [3]**, which is located on the opposite side, a few turns clockwise.

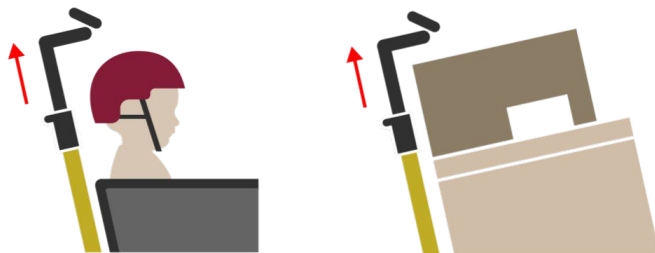

Check the tightening value of the screws after approx. 500 km and then regularly as part of the service intervals, but at least once a year. You can find the correct tightening values on page 50.



Do not adjust the height while driving. This could lead to a fall.



To avoid a fall or accident, the stem adapter must be replaced after it has been damaged.



Never pull the stem adapter further than the embossed maximum marking out of the steering tube!



If you want to transport children, pay attention to the height of the handlebar. When driving, the handlebar must be able to turn freely over the children's heads. Make sure there is enough space between the top edge of the helmet and the handlebar.

Quick releases

The supplied quick-release clamps are devices that, instead of a screw connection, can quickly fix components on your YOONIT without tools. With the force that you exert on the quick release lever, you clamp it in one direction and open it in the other direction. You can adjust the resistance of the clamping with the adjusting nut **[2]** when the quick release lever **[1]** is open.

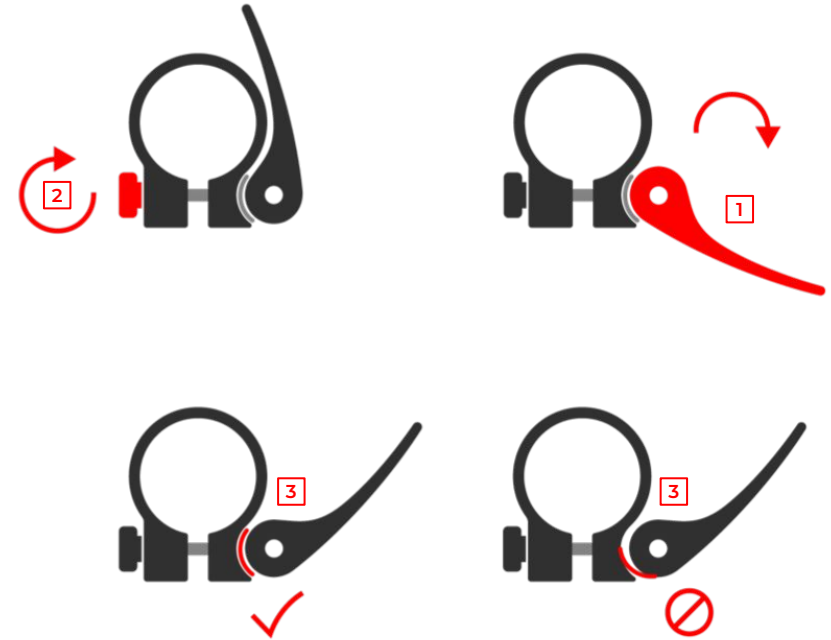
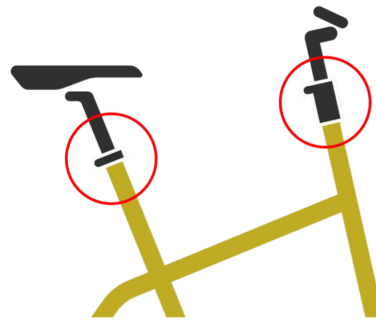

The holding force of the quick release is set correctly if you feel counter-pressure when you close the quick release from halfway through the lever travel. At the end of the lever path, enough force must be required that you need the force of the ball of your hand to close it.



Before you fix the quick release, make sure that the silver half-moon shell **[3]** is flush with the curve of the quick release lever. If the half-moon shell **[3]** is crooked, the clamping function can be impaired and the quick release can be damaged!



Make sure all quick releases are securely closed before you set off. The closed quick release lever **[1]** must lie close to the frame and always point against the direction of travel so that it is not opened due to unintentional contact while the vehicle is in motion.

Loading safely



Correct loading is an important prerequisite for safe and comfortable driving. Before you set off, please note the following:

- Is the carrier firmly fixed by the quick release?
- Is your child buckled up correctly or is the load secured?
- Has the permissible total weight been taken into account?
- Is the load evenly arranged?
- Can the steering be moved freely as far as it will go and can the wheels turn freely without being blocked by the load?
- Does the tire pressure match the requirements of your journey?
- Are the lights and reflectors exposed so that your visibility is guaranteed?



The weight of the load should determine your driving style. A child or a heavy load affects the driving and braking behavior of your YOONIT. The steering is exposed to increased forces and the braking distance can be longer. So drive defensively and with foresight.

Fastening load carrier

Your YOONIT is equipped with the Unique Adapt System. Thanks to the three quick-release brackets, the various load carriers can be mounted quickly and without tools. Your YOONIT can be transformed from a family vehicle into a load transporter in a very short time. The Unique Adapt System offers a platform for a variety of individual transport solutions.



YOONIT offers several transport solutions for different needs:

- Smart Carrier**
- Job Carrier**
- Family Carrier**
- Base Carrier**
- Euro Carrier**

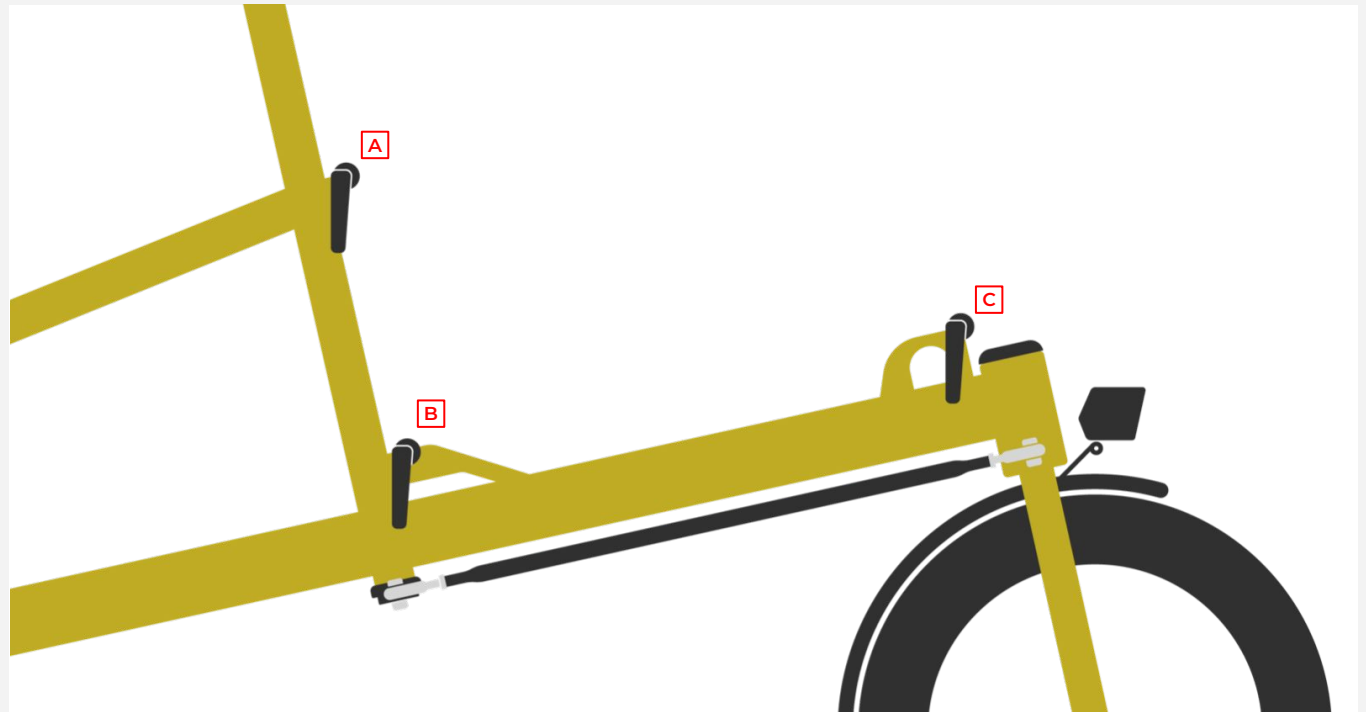

Smart Carrier

The YOONIT Smart Carrier is designed for the everyday transport of shopping goods or picnic equipment. The loading basket can be rotated 180 degrees, which means that the transport spectrum is expanded to include large-volume goods.

The two-part Smart Carrier is basket and loading area in one. By turning the basket, you can remove the side limitation and increase the loading height. The rear frame offers you additional fastening options to secure your load.

Components

1x Rear frame (aluminum tube) [1]

1x Basket (aluminum tube), reversible [2]

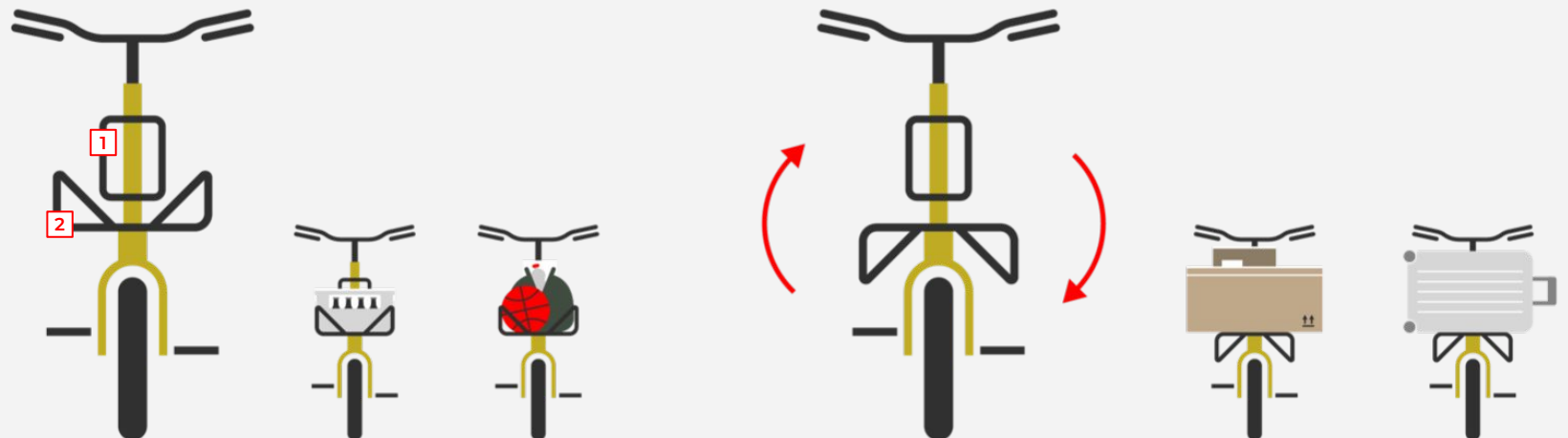

Mounting

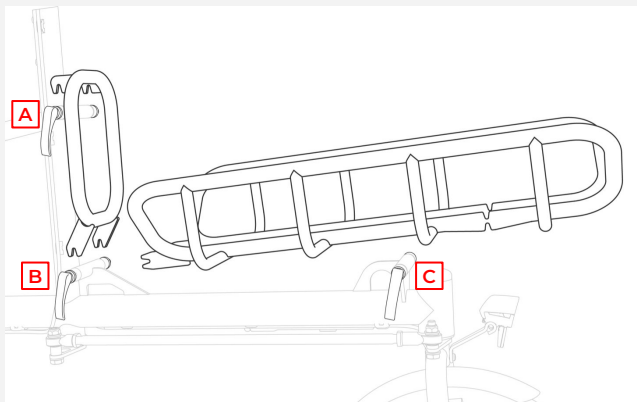

Step 1 Inserting back frame and basket

At the beginning, open the three quick releases of the Adapt system and unscrew them as much as possible so that you have enough space to insert the carrier.

Place the rear frame by putting its pairs of dropouts on the quick release axles **[A]** and **[B]**. Then take the basket and first thread it into the mounting point **[B]**. Then slowly lower it until the other pair of dropouts come to rest on the quick release axle at mounting point **[C]**.

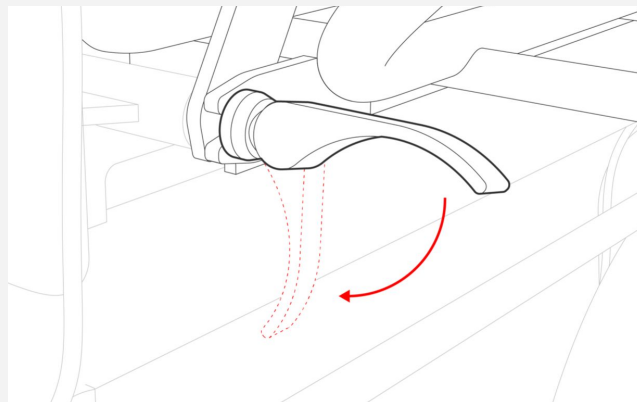

Step 2 Tightening the levers

Check that all pairs of dropouts lie on the axles of the quick release. Now screw the quick releases tight and tighten the levers.

Make sure that the required clamping takes place at all three mounting points. The dropouts must sit firmly and without a gap between the mounting tube and the quick release.

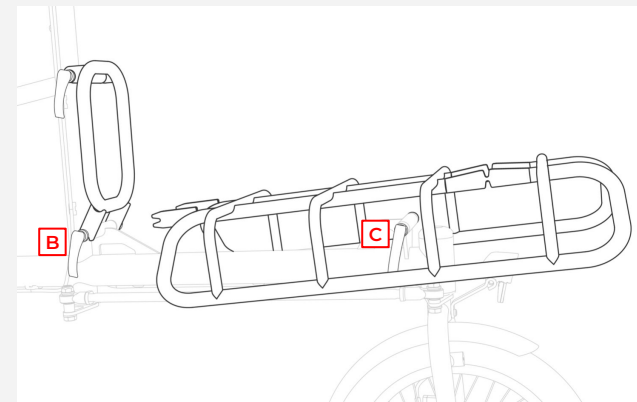

Step 3 Turning the basket

If you want to convert the basket into a loading area with no lateral limitation, loosen the quick release at points **[B]** and **[C]**. Unscrew it to the maximum so that you have enough space. First lift the basket out of the anchorage at point **[C]** and then pull it forward out of the holder **[B]**. Turn the basket and reattach it as described under "Step 1".



When assembling your carrier, take your time and proceed carefully. If you are unsure about the assembly, let your service partner support you. It is important that the carrier is firmly connected to the Adapt system.



Before every ride, make sure that all pairs of dropouts are hooked onto the quick release axles and that the quick releases are tight. This is the only way to ensure that the carrier cannot come loose during the journey.

Job Carrier

The YOONIT job carrier can be used to transport a wide variety of types of goods. The recesses in the loading area offer almost unlimited lashing options.

Components

1x Back plate (PP) on aluminum profile [1]

1x Base plate (PP) on aluminum profile [2]

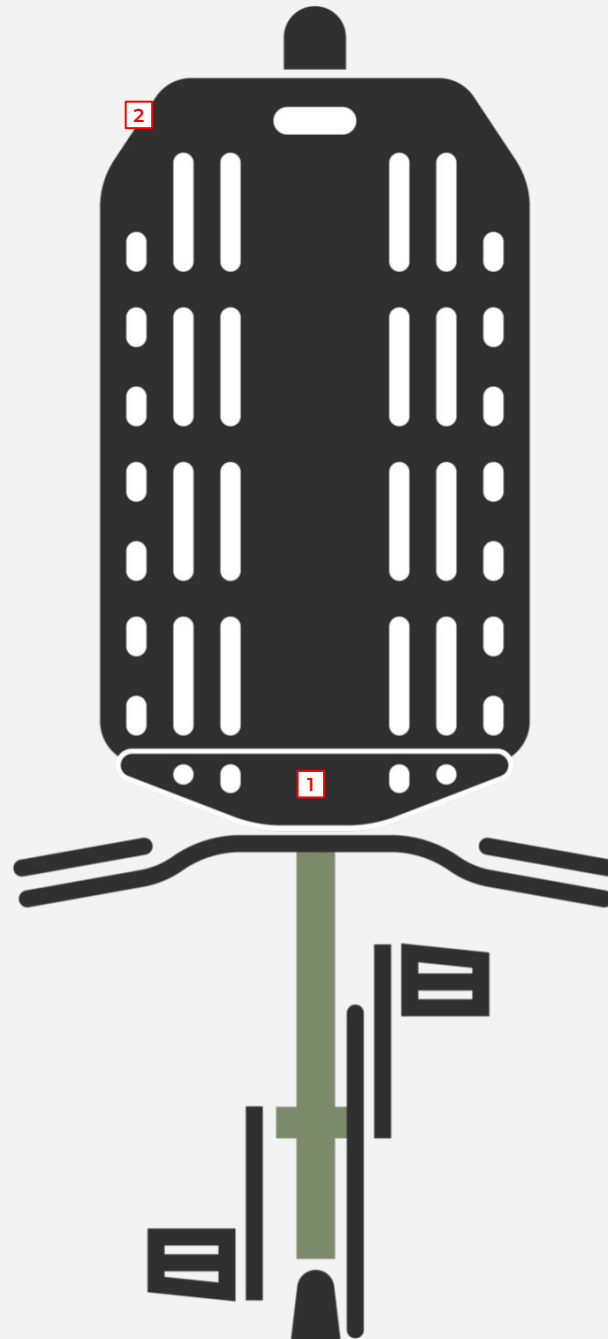

Loading and lashing

If you use the job carrier for transport, secure your cargo conscientiously. For example, you can fasten it with quick release straps so that it does not slide sideways from the carrier when cornering or forwards during braking maneuvers.



Inadequately secured cargo can result in accidents with personal injury and property damage. Pay attention to your safety and that of those around you.

Mounting

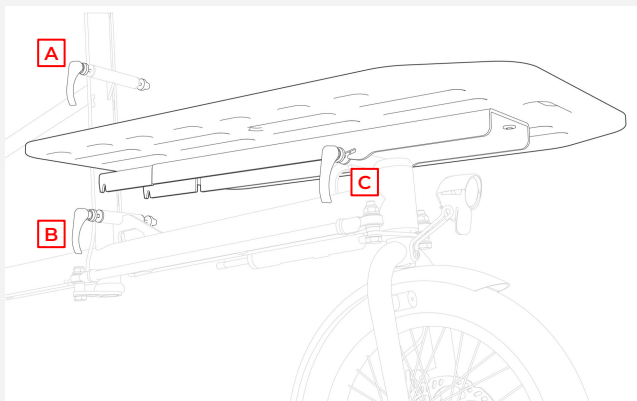

Step 1 Inserting the base plate

At the beginning, open the three quick releases of the Adapt system and unscrew them as much as possible so that you have enough space to insert the carrier.

Hold the base plate at a slight angle and first thread it into the mounting point **[C]**. Then slowly lower it until the rear pair of dropouts come to rest on the quick release axle at mounting point **[B]**.

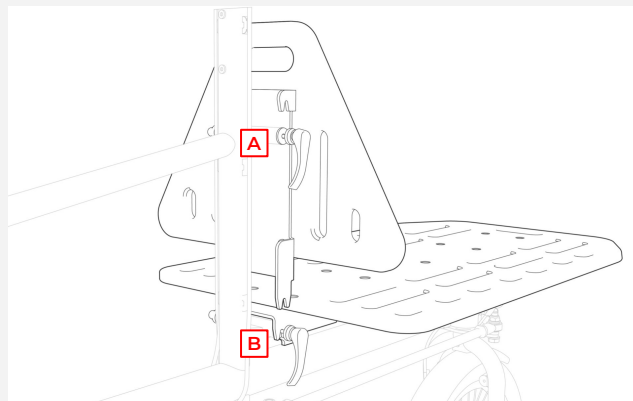

Step 1 Inserting the back plate

Place the backplate by putting the pairs of dropouts on the quick release axles **[A]** and **[B]**.

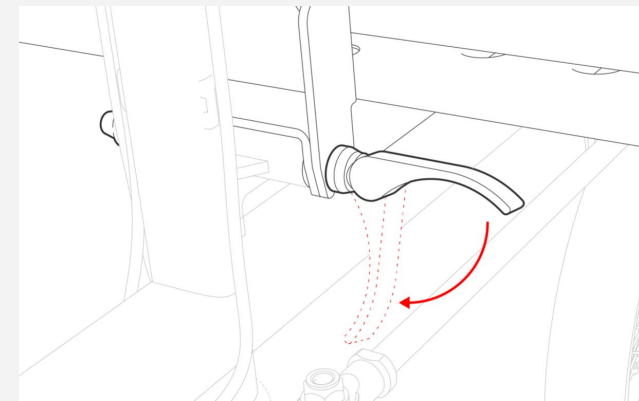

Step 3 Tightening the levers

Check that all pairs of dropouts lie on the axles of the quick releases. Now screw the quick releases tight and tighten the levers.

Make sure that the required clamping takes place at all three mounting points. The dropouts must sit firmly and without a gap between the mounting tube and the quick release.

S



When assembling your carrier, take your time and proceed carefully. If you are unsure about the assembly, let your service partner support you. It is important that the carrier is firmly connected to the Adapt system.



Before every ride, make sure that all pairs of dropouts are hooked onto the quick release axles and that the quick releases are tight. This is the only way to ensure that the carrier cannot come loose during the journey.

Family Carrier

The YOONIT Family Carrier supports you in a wide variety of everyday situations. It offers the largest transport volume, whether for shopping, transporting your children or your dog.

Components

- 1x Aluminum frame [1]
- 1x Textile-Inlay [2]
- 1x Base plate [3]



For the safe transport of up to two children we offer an optional child seat. You can find more information under the chapter family child seat.

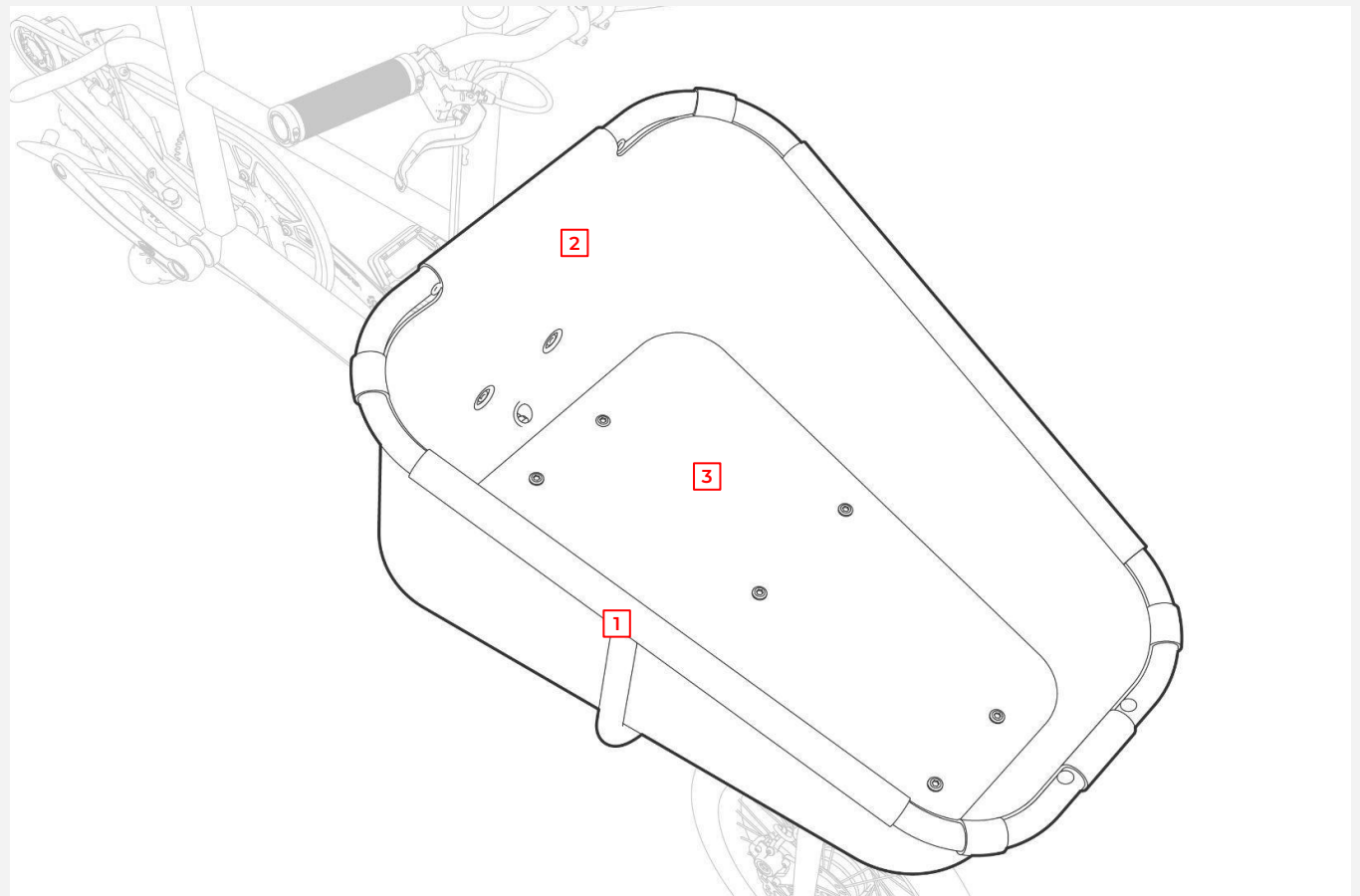

Assembling

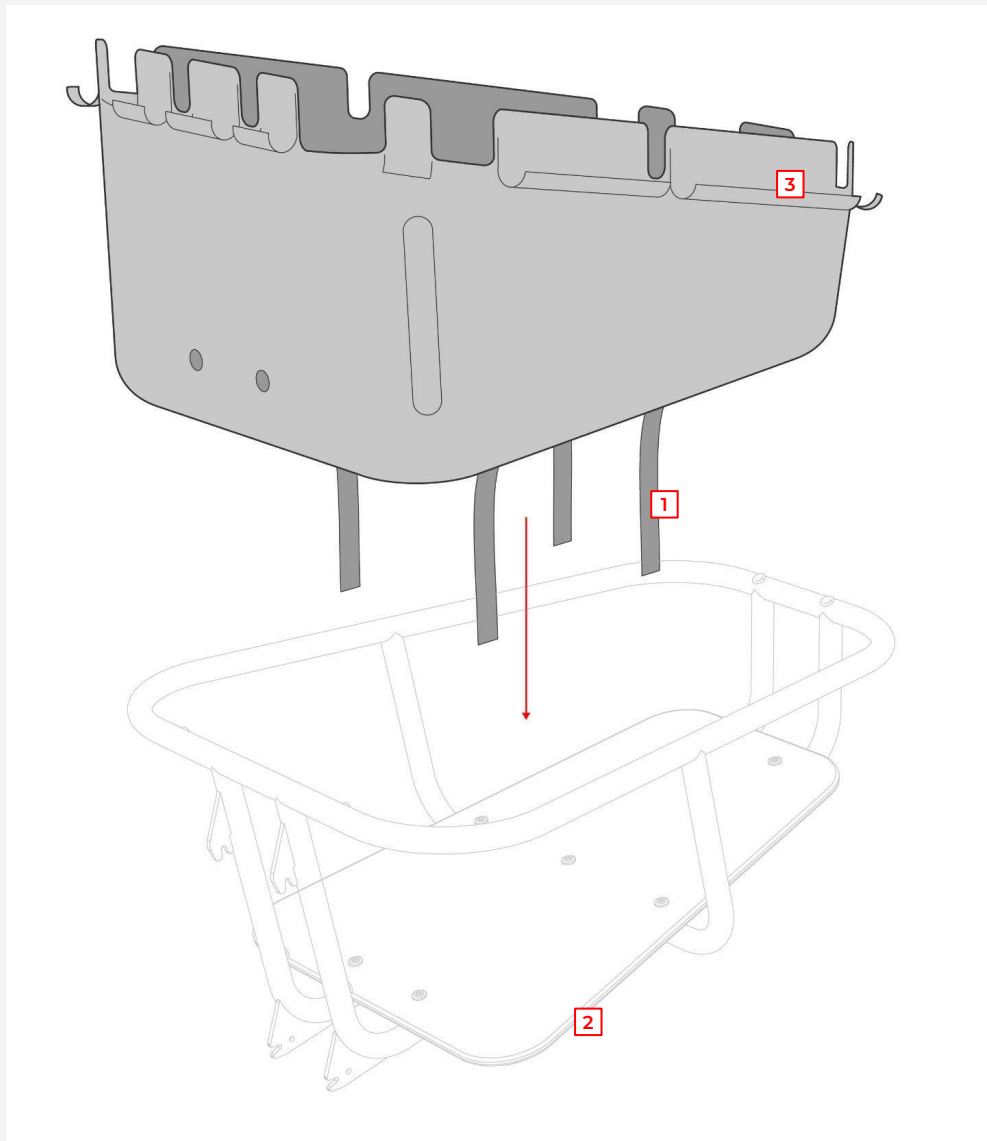

Step 1 Inserting the inlay

First unfold the inlay and open the long Velcro straps **[1]**. Insert the inlay into the carrier frame from above, paying attention to its orientation. Pull the lower hem with the inside elastic band all the way around under the bottom panel **[2]**. Close all Velcro straps **[3]** on the upper edge of the inlay around the tube surrounding the carrier.

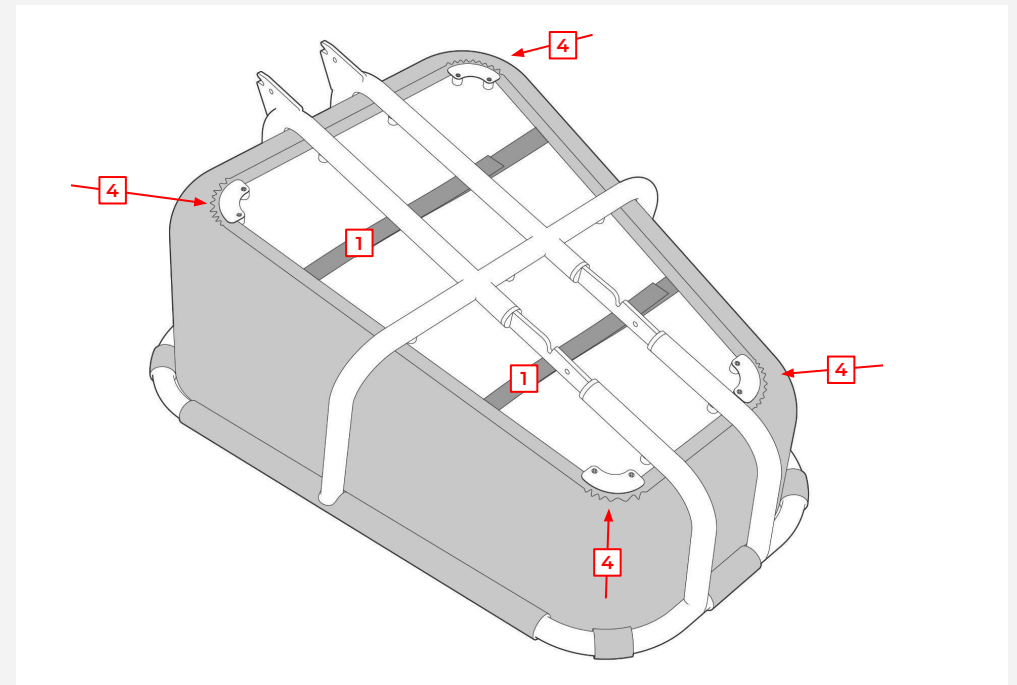

Step 2 Fixing the underside

Turn the carrier over and ensure that the seam of the inlay goes through the four cable guides **[4]** in the corners on the underside of the base panel. Finally, close the transverse Velcro stripes **[1]**.

Mounting

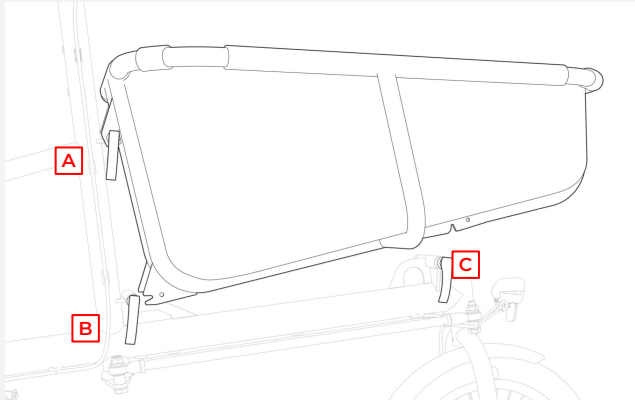

Step 3 Aligning the carrier

The Family Carrier is connected to the Adapt system at three points. To attach the carrier, loosen the three quick releases so that they can take up the carrier dropouts.

Hold the Family Carrier slightly tilted backwards and start by carefully hooking it into place at the attachment point **[A]**. When the pair of dropouts lies on the quick release axle, you can slowly lower the carrier forward.

Now make sure that the two remaining pairs of dropouts come to rest on the quick release axles of the mounting points on the down tube **[B]** and **[C]**.

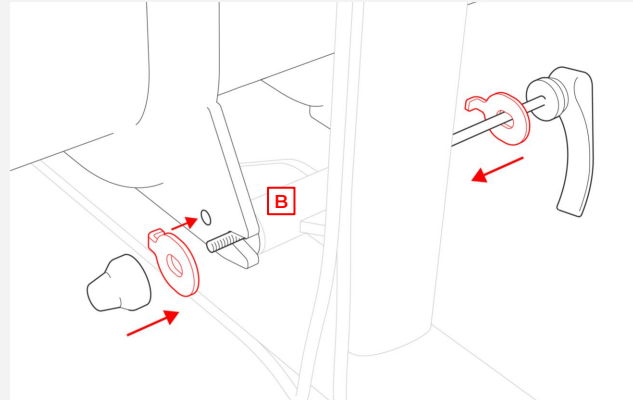

Step 4 Inserting the retaining washers

Loosen and remove the quick release at the mounting point **[B]**. Then place the two retaining washers by pushing the hooks of the washers into the holes on the dropouts.

Now you can reattach the quick release. Guide it through the retaining washers, the dropouts and the receiving tube.



When assembling your carrier, take your time and proceed carefully. If you are unsure about the assembly, let your service partner support you. It is important that the carrier is firmly connected to the Adapt system.

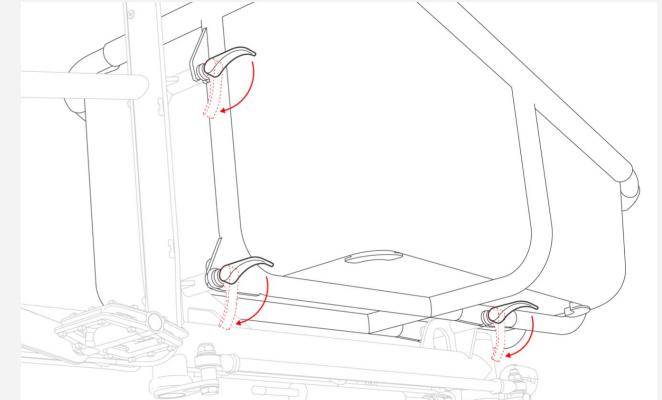

Step 5 Tightening the levers

Check that all three pairs of dropouts lie on the axles of the quick releases. Now screw the quick releases tight and tighten the levers.

Make sure that the required clamping takes place at all three mounting points. The dropouts must sit firmly and without a gap between the mounting tube and the quick release.



Before every ride, make sure that all pairs of dropouts are hooked onto the quick release axles and that the quick releases are tight. This is the only way to ensure that the carrier cannot come loose during the journey.



Taking along pets
Pets can be taken along in the Family Carrier if they are properly secured. Make sure that your pet cannot fall or jump out of the carrier while driving.

Child Seat

In the YOONIT Family Carrier you can transport your children with the optionally available child seat. The combination of a fixed backrest, back and seat cushion cover and a 5-point belt system enables up to two children to be carried safely.

The Child Seat is designed for children who can sit independently, weigh a maximum of 22 kg and are a maximum of 120 cm tall. Children may only be transported on the YOONIT with the original YOONIT Child Seat.

components

- 1x seat pad
- 2x five-point belts
- 1x backrest
- 4x M6 screws with hexagon socket
- 4x spacers

Required tools

- Allen key

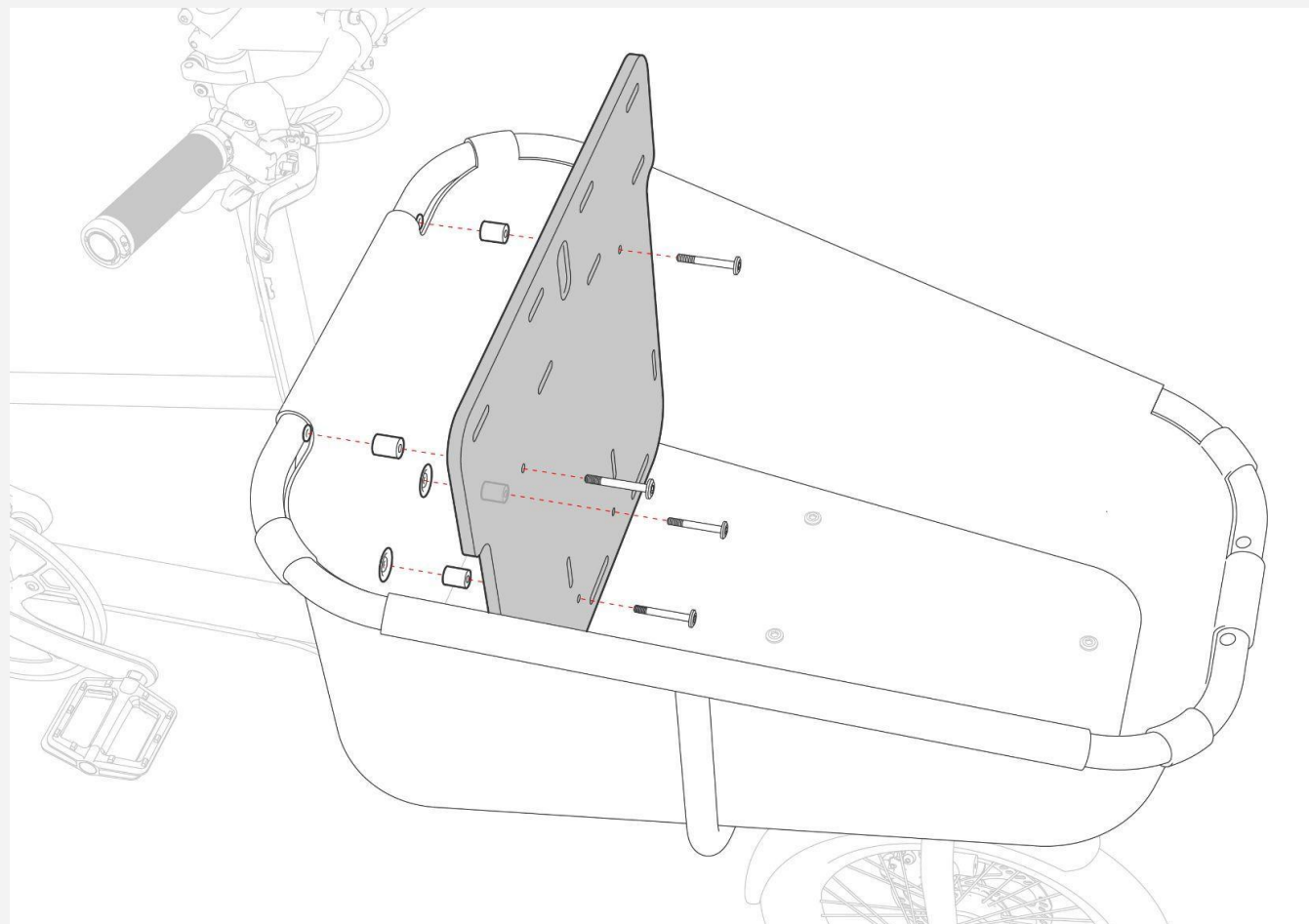

Step 1 Assembly of the backrest

Mount the backrest with the structured side facing forward at the four mounting points in the Family Carrier. First screw in all four screws evenly by hand, starting with the bottom two by inserting them through the backrest and one spacer each. Make sure that the spacers run cleanly through the two eyelets in the fabric inlay and that they do not pinch these. Use a size 5 Allen key to finally tighten the screws.



Before riding, make sure that the handlebars can be turned freely over the heads of the children. If the distance between the brake levers and the children's helmet is too small, there is a risk of accident or injury.



The transport of children is only permitted in the YOONIT Family Carrier with the YOONIT Child Seat. Attaching child seats from other manufacturers is not permitted.

Assembling

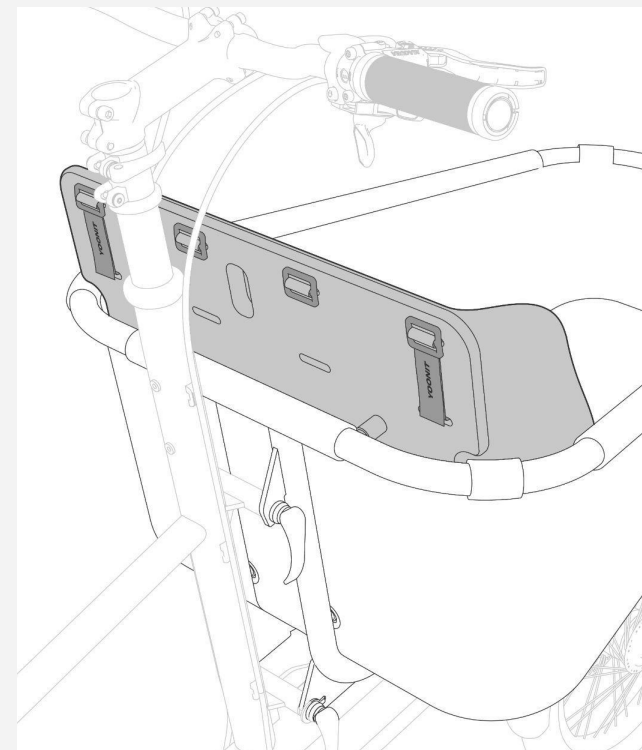
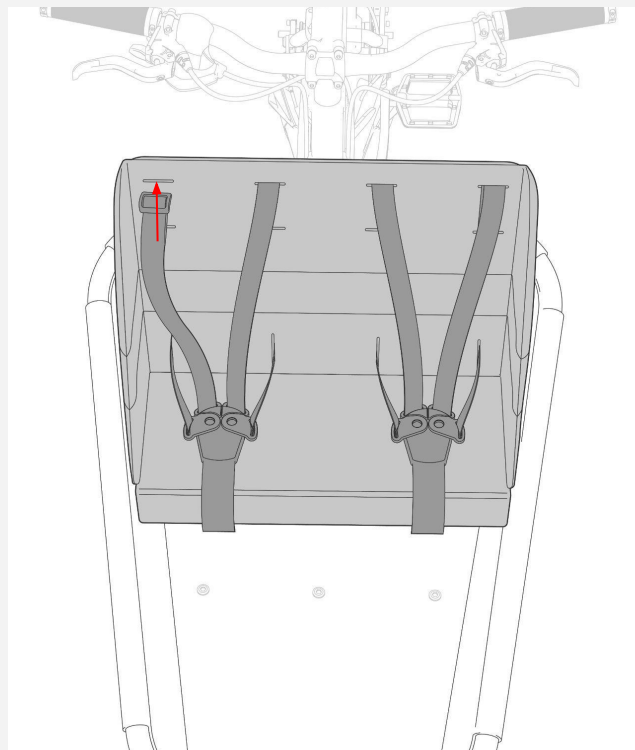
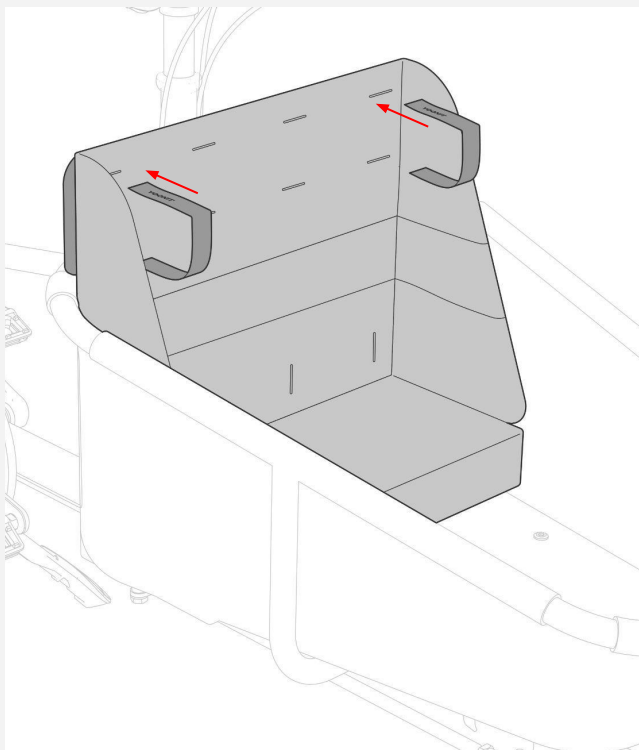

Step 2 Installing the seat pad

Place the seat pad in front of the backrest. Use the Velcro straps included with the set to fix it. Guide the straps left and right through the buttonholes in the upholstery and the openings in the backrest and fasten them on the back of the backrest.

Assemble the belt system by laying the buckles flat on the ends of the belts and threading them through the buttonholes in the upholstery and the openings in the backrest as well.



The buttocks pad of the seat pad consists of three padding layers on top of each other. They can be unfolded and used to pad the entire carrier floor, for example for transporting your pet, or as a seat pad away from the carrier.



If necessary, the fabric inlay of the carrier can be pushed up to give free access to the lower part of the rear of the backrest. It has an elastic band on the lower hem and two detachable Velcro straps under the base plate.

5-point belts

Positioning the belts

You can take up to two children with you in the Child Seat and buckle them up safely. For the transport of a single child, it is possible to place a belt unit in the middle of the backrest. This ensures a balanced weight distribution, which in turn benefits driving safety and driving behavior.

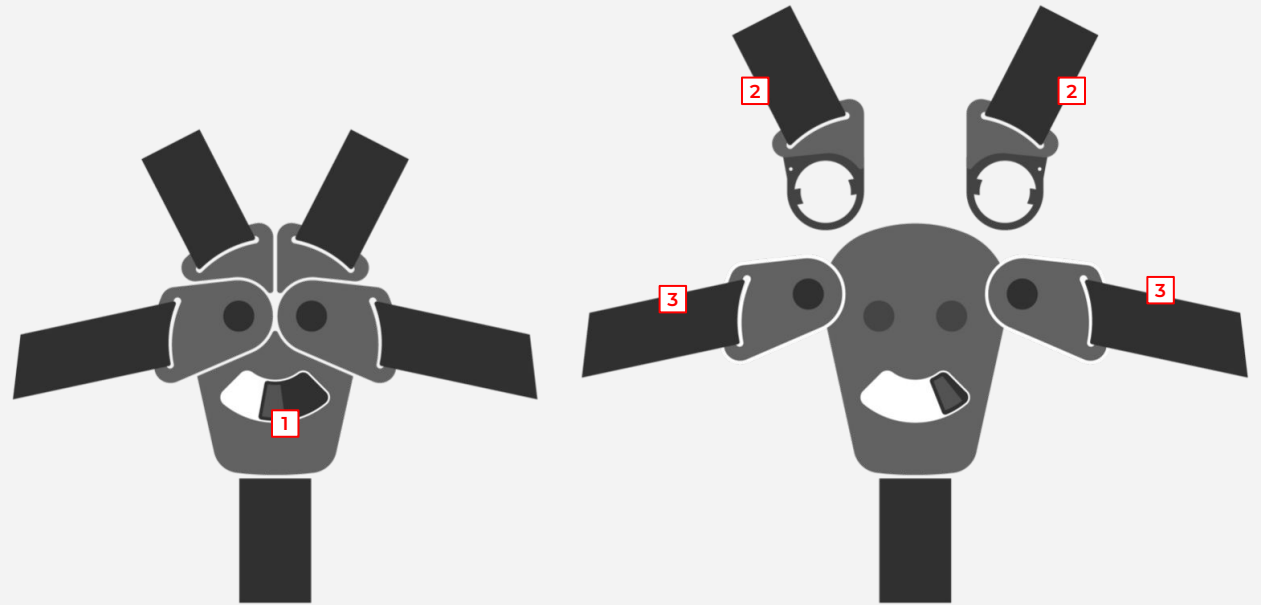
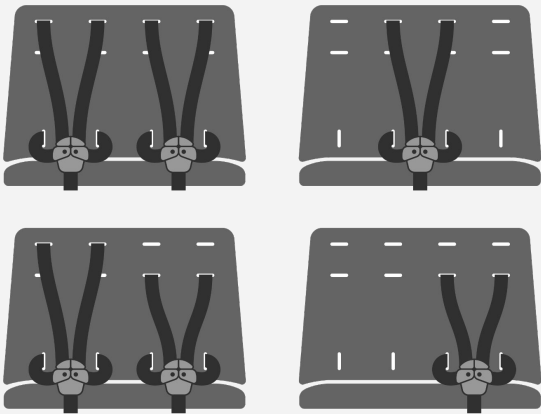

Application of the belt buckles

The 5-point belt system is held together by the belt buckle / snap buckle, which is equipped with an sliding mechanism to be opened and closed.

The shoulder [2] and waist belt [3] can be opened together or separately.

Open the buckle by pushing the sliding bolt to the side.

Child Seat 2

In the YOONIT Family Carrier you can transport your children with the optionally available Child Seat 2. The combination of a fixed backrest, back and seat padding as well as a 5-point belt system allows up to two children to be transported safely.

The child seat is designed for children who can sit independently and are a maximum of 120 cm tall including a helmet. Children may only be transported on the YOONIT with the YOONIT Child Seat.

components

- 1x seat pad
- 2x five-point belts
- 1x backrest
- 4x M6 screws with hexagon socket
- 4x spacers

Required tools

- Allen key

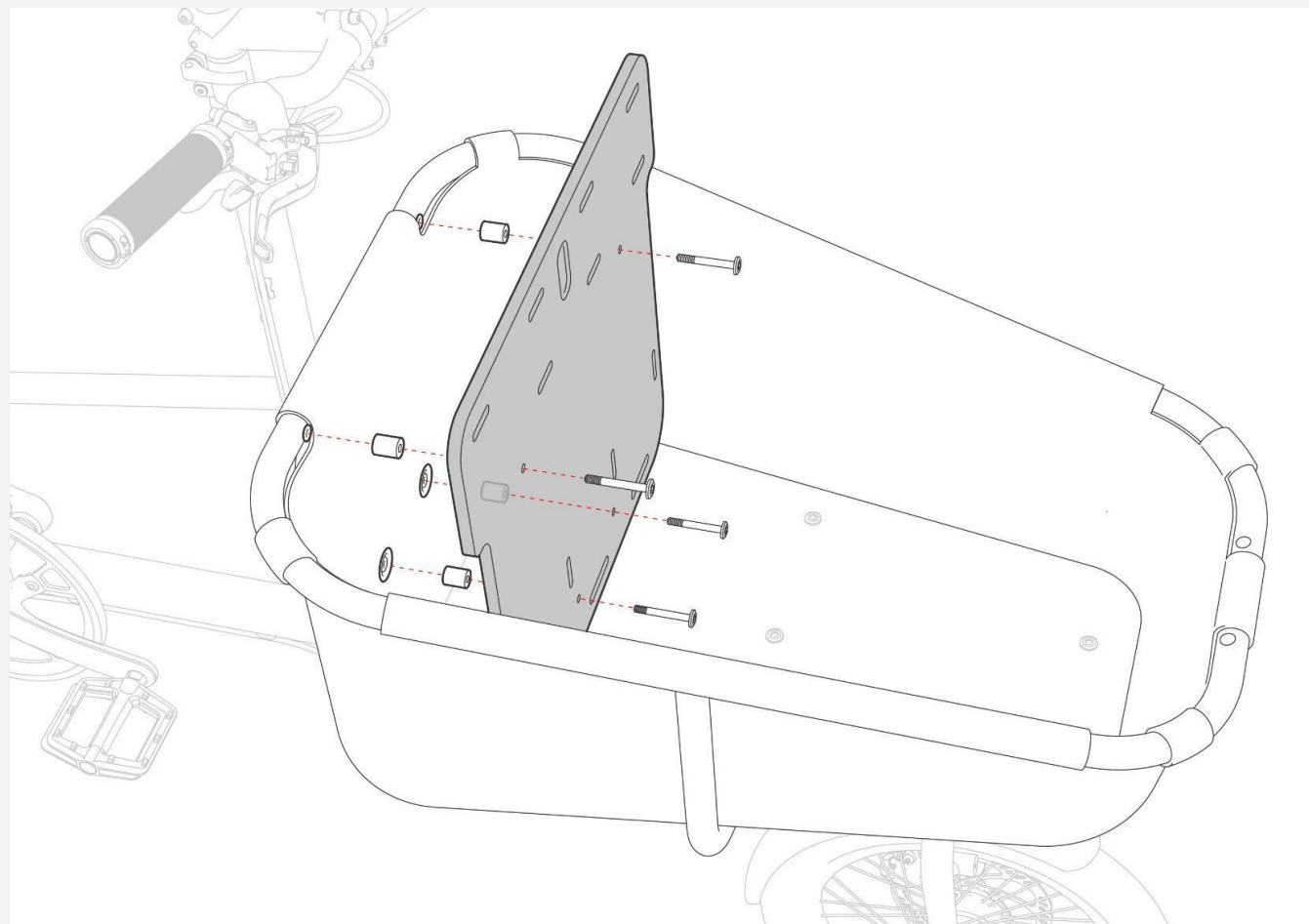

Step 1 Assembly of the backrest

Mount the backrest with the structured side facing forward at the four mounting points in the Family Carrier. First screw in all four screws evenly by hand, starting with the bottom two by inserting them through the backrest and one spacer each. Make sure that the spacers run cleanly through the two eyelets in the fabric inlay and that they do not pinch these. Use a size 5 Allen key to finally tighten the screws.



Before riding, make sure that the handlebars can be turned freely over the heads of the children. If the distance between the brake levers and the children's helmet is too small, there is a risk of accident or injury.



The transport of children is only permitted in the YOONIT Family Carrier with the YOONIT Child Seat. Attaching child seats from other manufacturers is not permitted.

Assembling

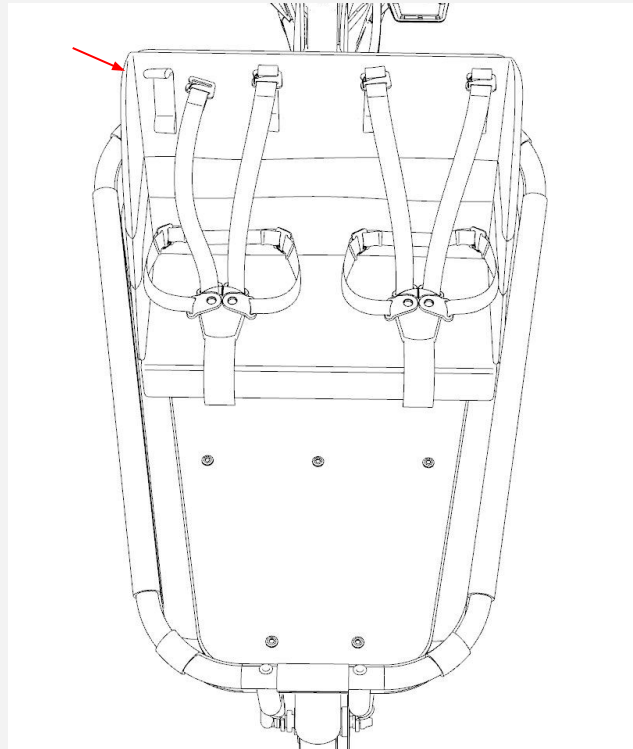
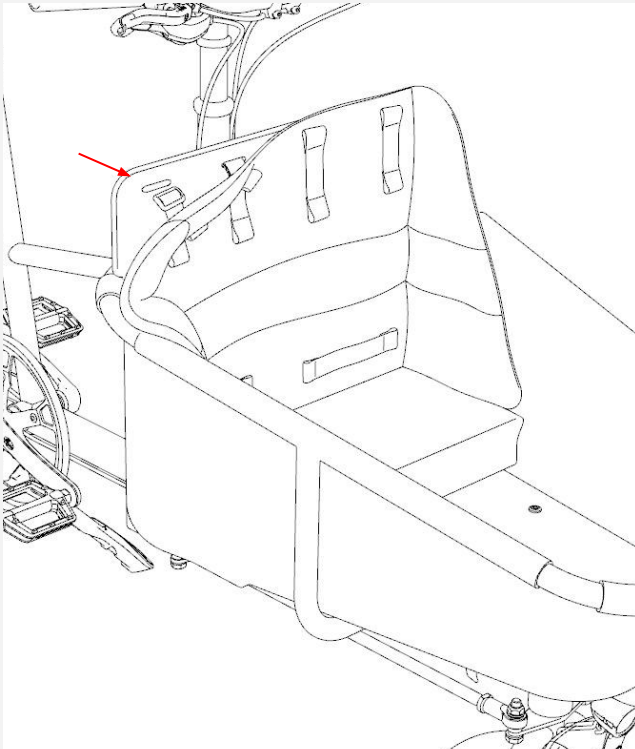

Step 2 Installing the seat pad

Bring the seat cushion into position in front of the backrest. Use the buckles sewn on its back to secure it to it. Align the buckles flat and thread them through the corresponding openings in the backrest.

Attach the belt systems by hooking the G-hooks at the ends of shoulder and hip belts into the corresponding tabs on the front of the seat cushion. Attach the large buckles on the crotch straps directly at the bottom of the backrest by laying them flat and threading them through the appropriate openings.



The buttocks pad of the seat pad consists of three padding layers on top of each other. They can be unfolded and used to pad the entire carrier floor, for example for transporting your pet, or as a seat pad away from the carrier.



If necessary, the fabric inlay of the carrier can be pushed up to give free access to the lower part of the rear of the backrest. It has an elastic band on the lower hem and two detachable Velcro straps under the base plate.

5-point belts

Positioning the belts

You can take up to two children with you in the Child Seat and buckle them up safely. For the transport of a single child, it is possible to place a belt unit in the middle of the backrest. This ensures a balanced weight distribution, which in turn benefits driving safety and driving behavior.

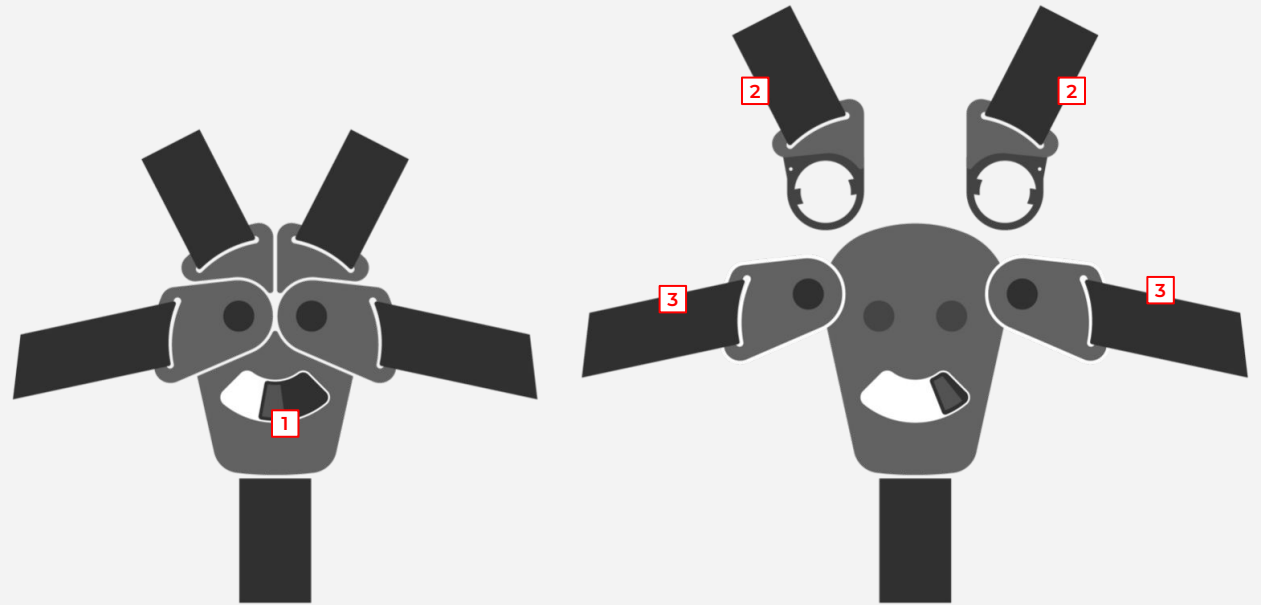
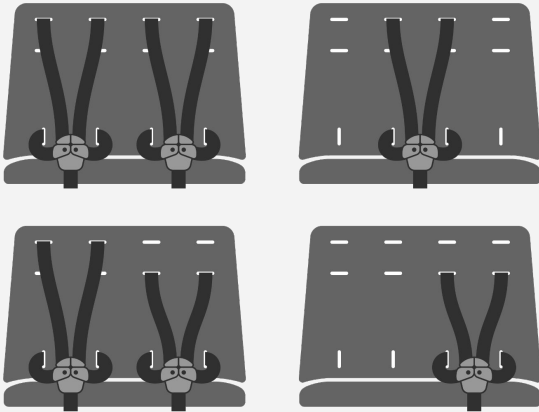

Application of the belt buckles

The 5-point belt system is held together by the belt buckle / snap buckle, which is equipped with an sliding mechanism to be opened and closed.

The shoulder [2] and waist belt [3] can be opened together or separately.

Open the buckle by pushing the sliding bolt to the side.

Cover

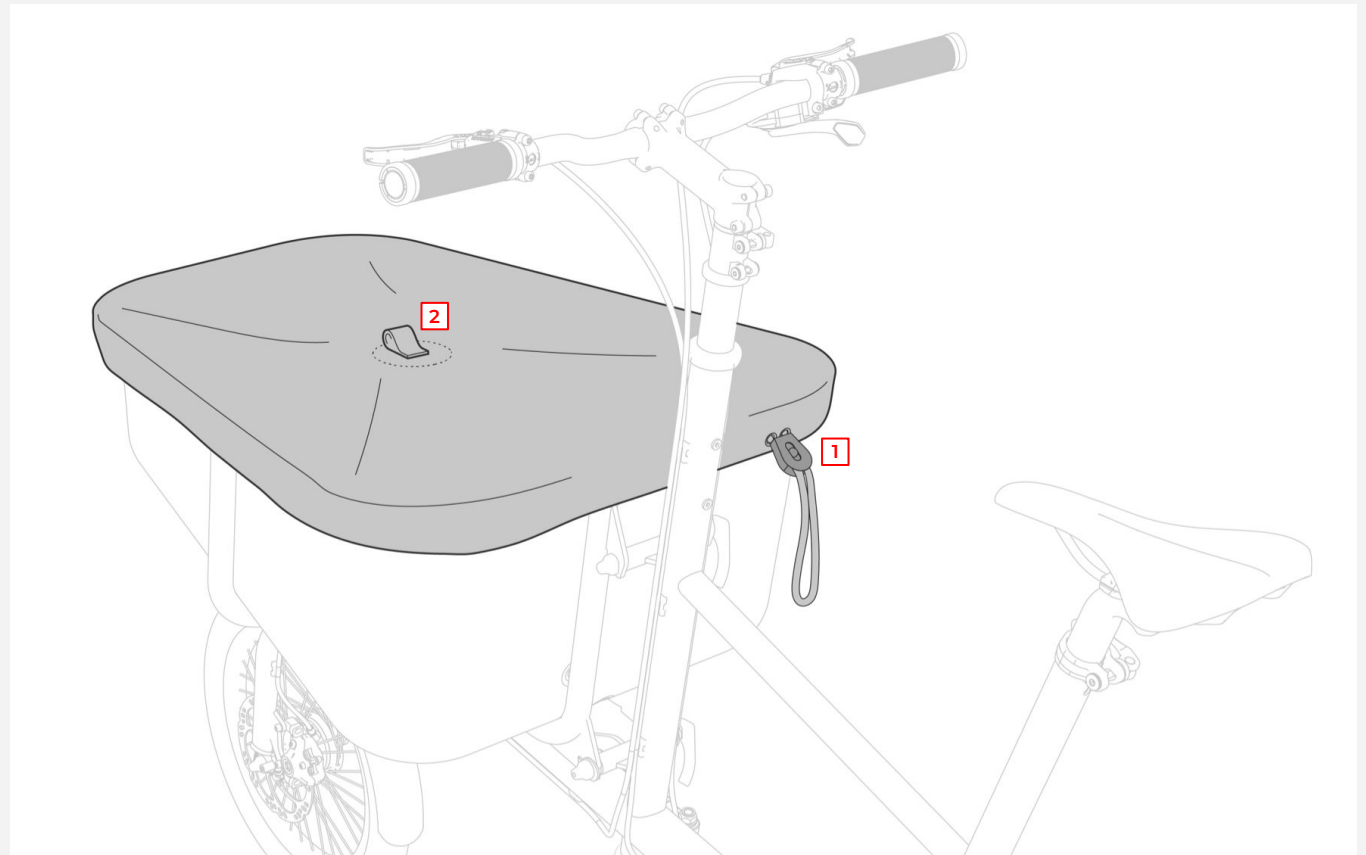

The Cover protects your load in the Family Carrier from rain and weather. It surrounds the carrier securely with a circumferential elastic band, both with and without the YOONIT Child Seat.

Simply put the cover over the Family Carrier so that the cord stopper **[1]** is on the right rear of the carrier. With this you can readjust the tension of the elastic if necessary.



If rainwater collects on the cover, you can easily remove it by pulling on the strap **[2] in the middle.**

Canopy

With the YOONIT Canopy your children ride protected from rain. Its aerodynamic shape offers little resistance to the wind, but plenty of headroom, even for bicycle helmets.

A replacement handlebar included in the scope of delivery reduces contact with the back panel of the canopy.

The Canopy has two side doors **[A]** and a removable back panel **[B]**. The two main struts of its frame are inserted into the front of the carrier frame and the entire canopy is braced to the rear.

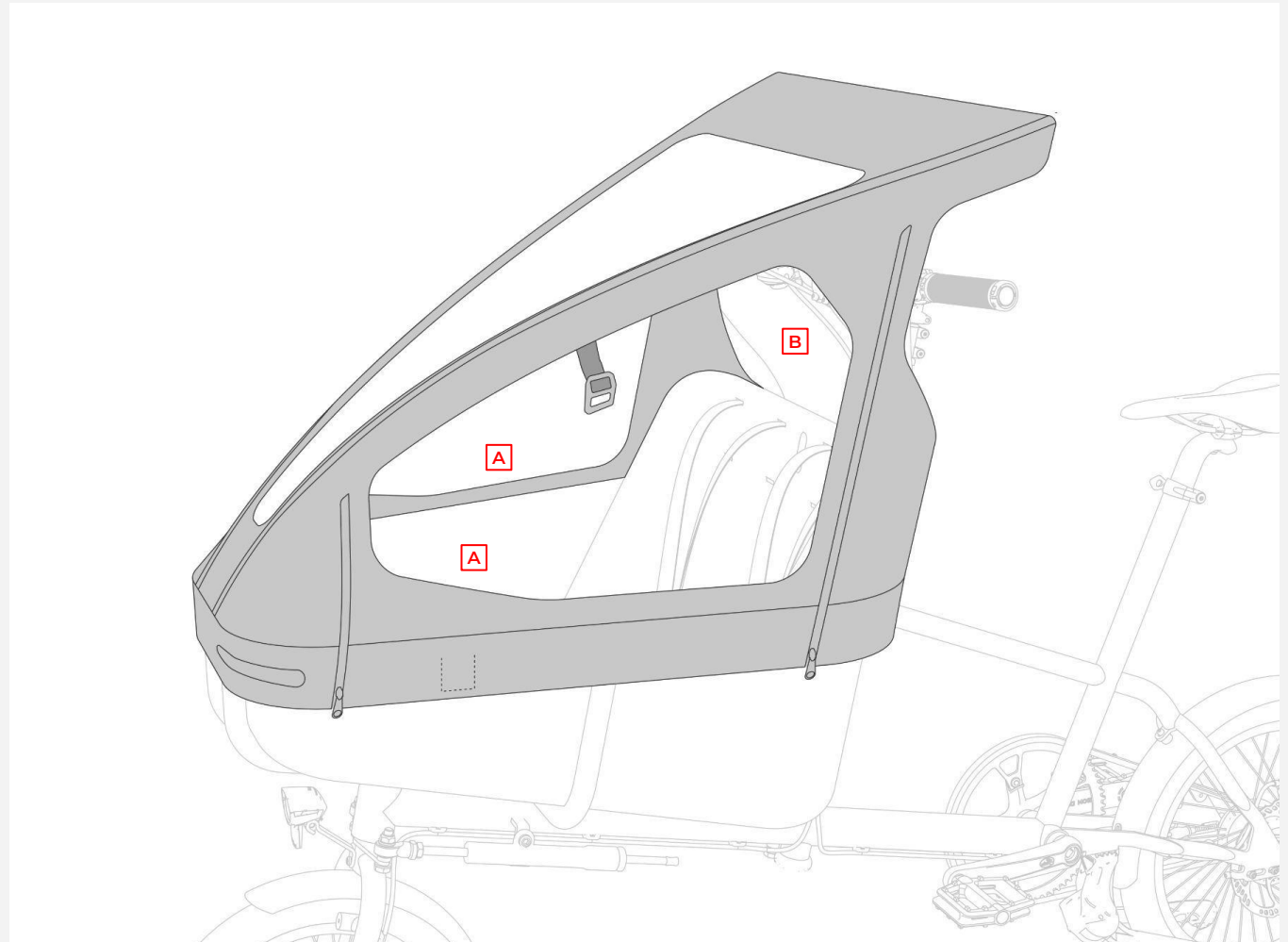

Components

- 1x Canopy
- 1x Back panel, removable
- 1x Replacement handlebar
- 1x 300 mm Replacement STEPS Kabel



The doors can be rolled up and held in this position with a flat hook and a loop. For quick access, you can also simply flip it up and fix it on the opposite side of the roof with the help of inserted magnets.

Assembling

Step 1 Attaching

The ends of the two main rods **[A]** are reinforced with stainless steel sleeves. Insert these two ends into the corresponding receptacles on the front of the carrier as far as they will go.

Close the four front Velcro straps **[B]** tightly around the surrounding Family Carrier tube.

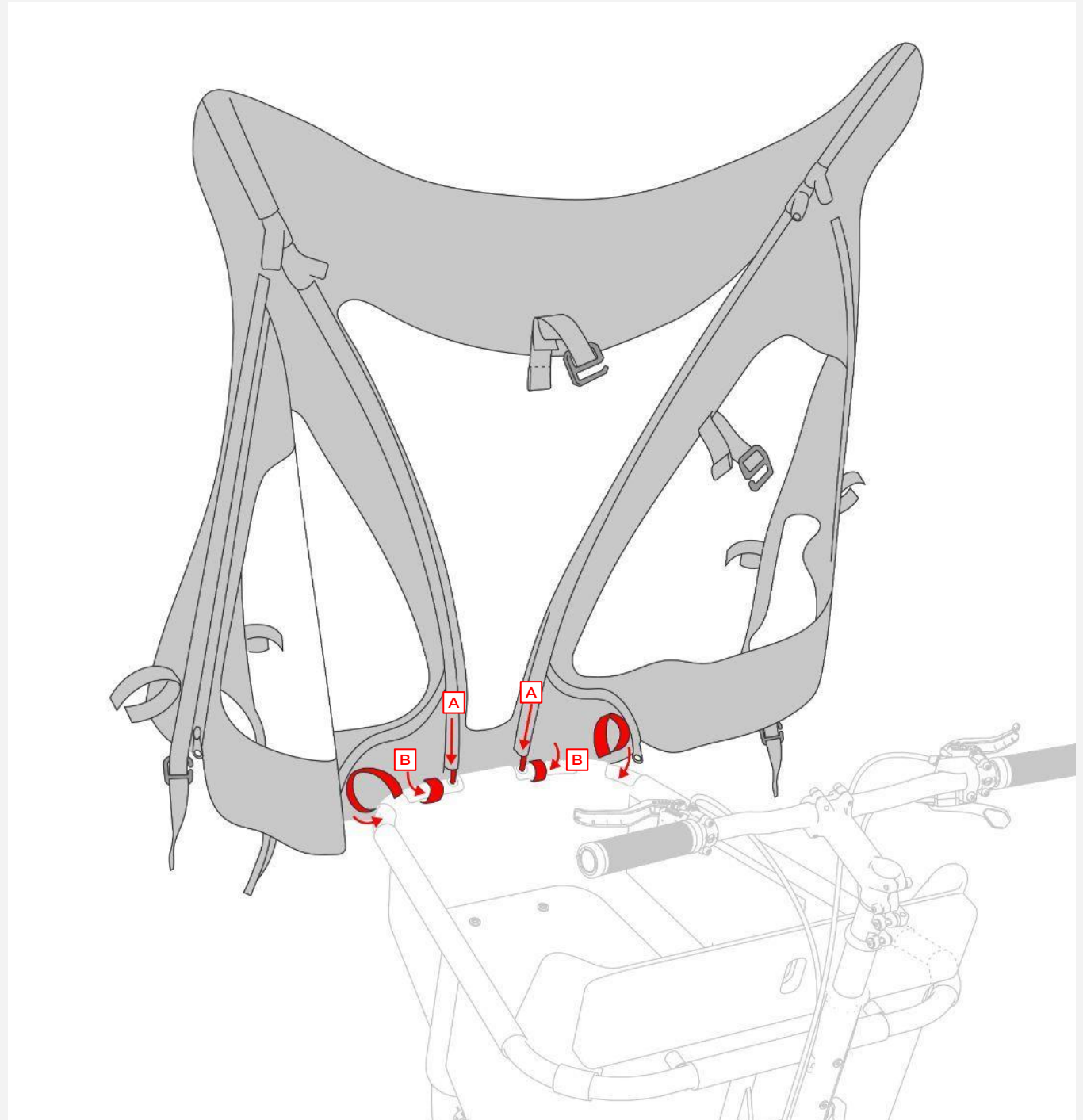

Assembling

Step 2 Bracing the canopy

Push the side rods [C] into the rear rubber side connectors [D]. Insert the roof rod [E] on one side into the free rubber side connector [F], then with a little force into the one on the opposite side. This will stretch the roof tight.

Finally, connect the Velcro strips [G] from roof and back panel.



The frame of the rain cover consists of fiberglass rods in order to fulfill its function. The rods have a smooth surface, are enclosed by the fabric and provided with protective caps at the ends. The roof rod is also sealed with a clear coat.



Be careful when handling fiberglass rods, especially at the ends there is a risk of splinters getting into the skin. When stiffening the canopy, make sure that you do not grip the rod at its ends.

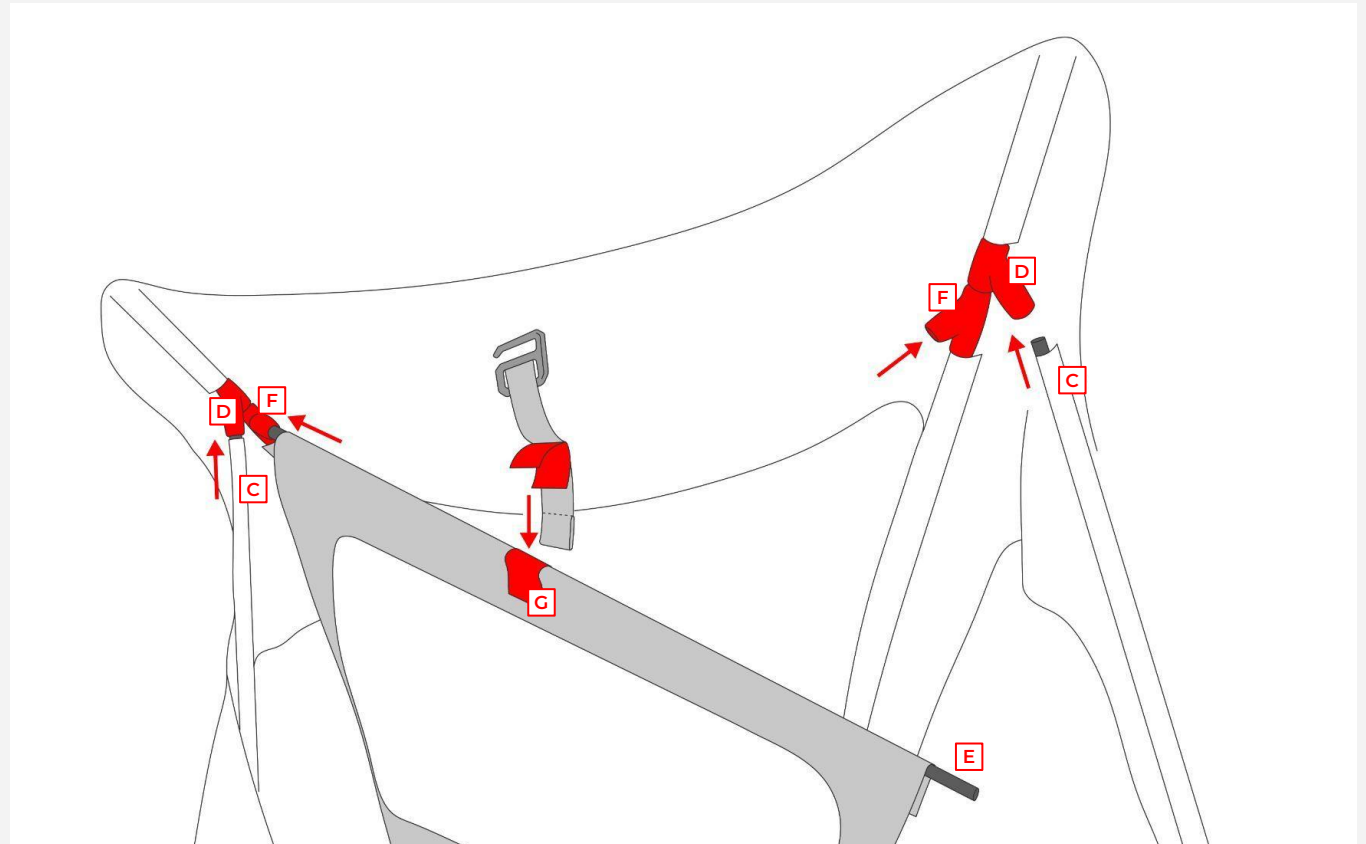

Assembling

Step 3 Fastening

Close the four rear Velcro straps **[H]** tightly around the Family Carrier tube, then hook the flat hooks **[I]** around the tube in the corresponding loop **[J]** and tighten the open end of the strap.

Finally, insert the back hook **[K]** into the opposite loop **[L]**.

Connect the rear wall to the carrier by looping the two expander hooks **[M]** around the spacer of the backrest screw connection on each side.

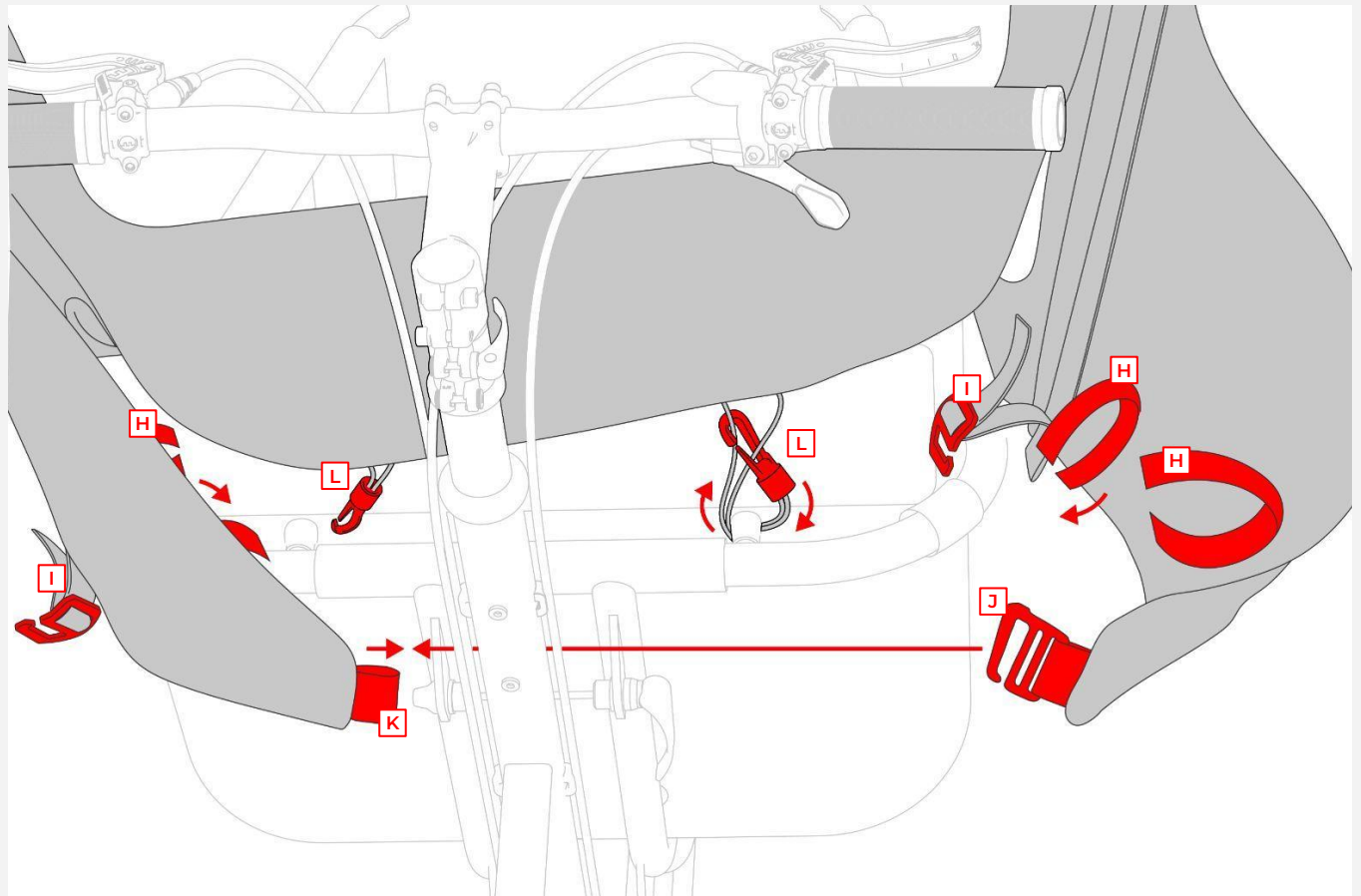

When the handle bar is turned, the contact between brake levers and back panel can lead to unwanted locking of the wheels and a loss of driving control. Before using the back panel while driving, we recommend that you comprehensively deal with possible changes in driving behavior and, if necessary, do without the back panel. In case of doubt, this should only be used as protection against rain, if the bike is outside when not in use, exposed to the weather.



If not needed, the back panel can be removed without pulling the roof rod out of the rubber side connectors. The hem that the rod runs through at the top of the rear wall can be opened and closed by Velcro strips.



The back panel can also be easily rolled up and fixed in this position with a flat hook and a loop.

Dog Seat

The YOONIT Dog Seat is a padded inlay for the Family Carrier, made of durable CORDURA® fabric and equipped with a belt and carabiner to secure your pet. It allows your dog to ride along comfortably, but can also be used as a dog basket on the go or in your office.

The Dog Seat is designed for small to medium-sized dogs. For reinforcement, it has an internal frame made of GRP struts.

Components

- 1x Inlay, 2 parts
- 4x Ring-Straps
- 1x Dog Belt
- 1x Backrest
- 4x M6 Allen screw
- 4x Spacer

Benötigtes Werkzeug

- Allen key size 5

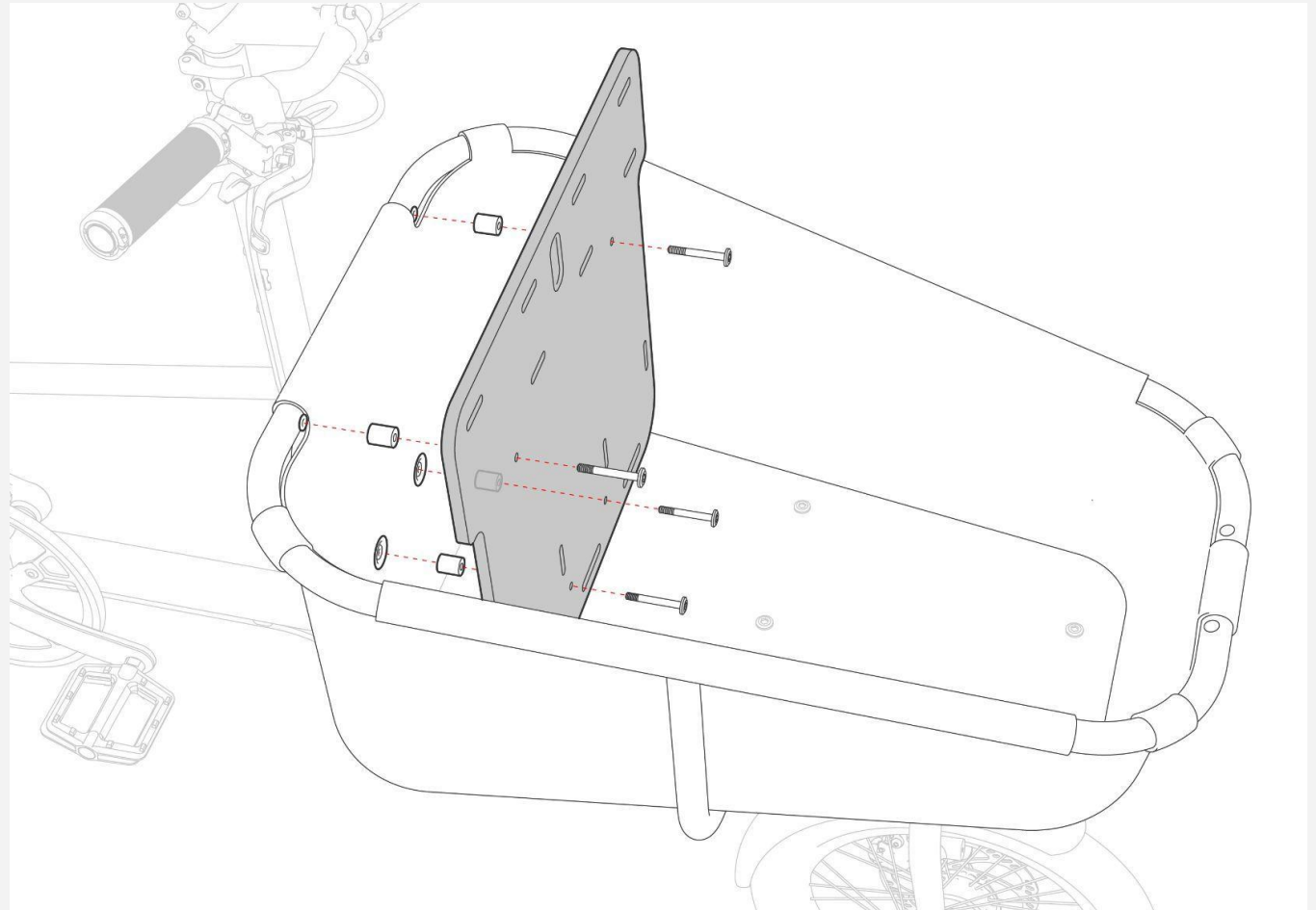

Step 1 Assembling of the backrest

The Dog Seat requires the fully assembled Family Carrier as a basis (see page 25). Place the backrest on the four mounting points in the Family Carrier with the textured side facing forward. First screw in all four screws evenly by hand, starting with the bottom two by guiding them through the backrest and one spacer each. Make sure that the spacers run neatly through the two eyelets in the fabric inlay not pinching them. Use a size 5 Allen key to finally tighten the screws.

Assembling

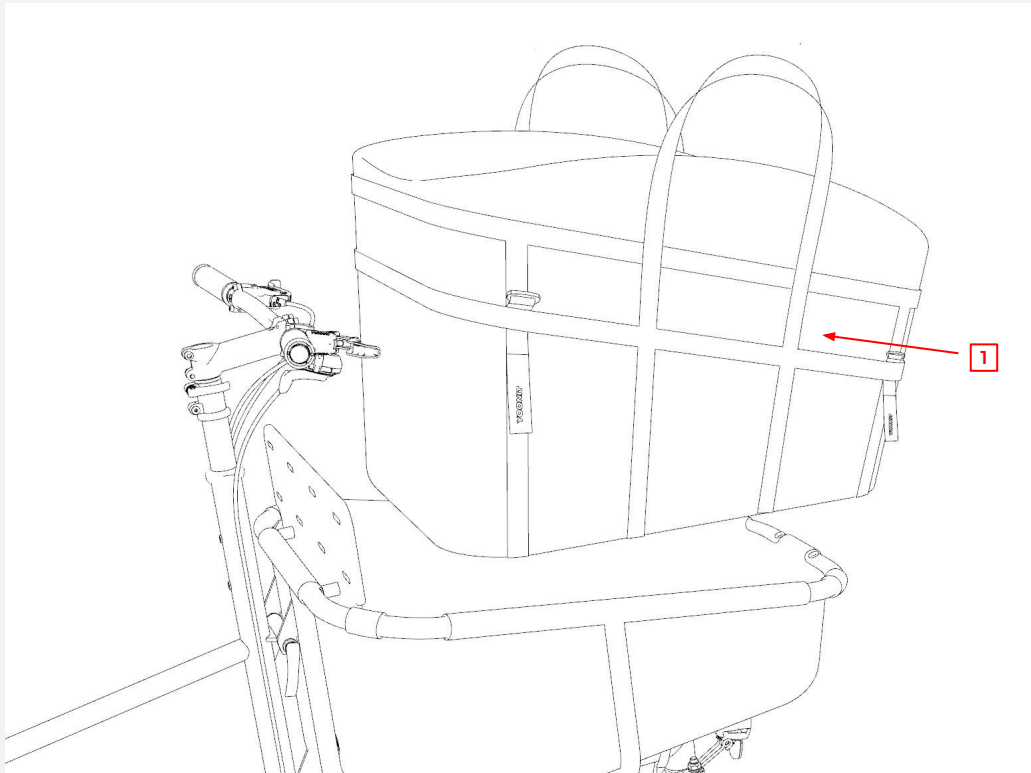

Step 2 Inserting the Dog Seat

Place the Dog Seat in the Family Carrier after zipping the wall and floor pads together. Note the alignment – the sewn-on webbing should run parallel to the edge of the carrier [1].

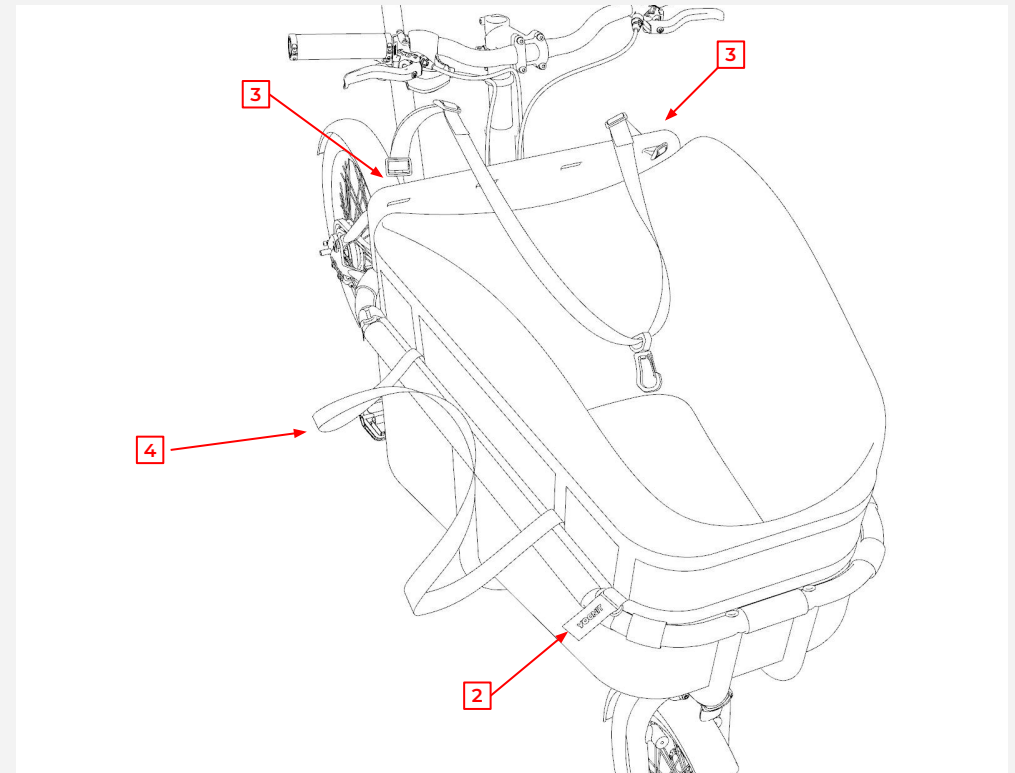

Step 3 Attachment

Fasten the Dog Seat in the corners to the surrounding tube of the carrier, guiding the four ring straps around the tube from below and through the eyelet [2]. Pull the Dog Belt through the recesses in the backrest as shown [3]. The carrying straps [4] can be pushed between the carrier and the dog seat.



Leash your dog with the dog belt in the carrier so that he cannot jump out while driving. There is a risk of accident or injury.



The carrying straps [4] should be pushed between the dog carrier and the dog seat while driving to avoid accidents.

Base Carrier

Boxes or crates can be mounted horizontally on the Base Carrier. Recesses on the loading area allow the use of belts, airline rails, locking bolts or different screw connections.

Components

- 1x base base plate
- 1x base back plate
- 2x base side plates
- 2x base spacer plate
- 16x washer M6
- 16x Locknut M6
- 16x Torx screw M6 x 16

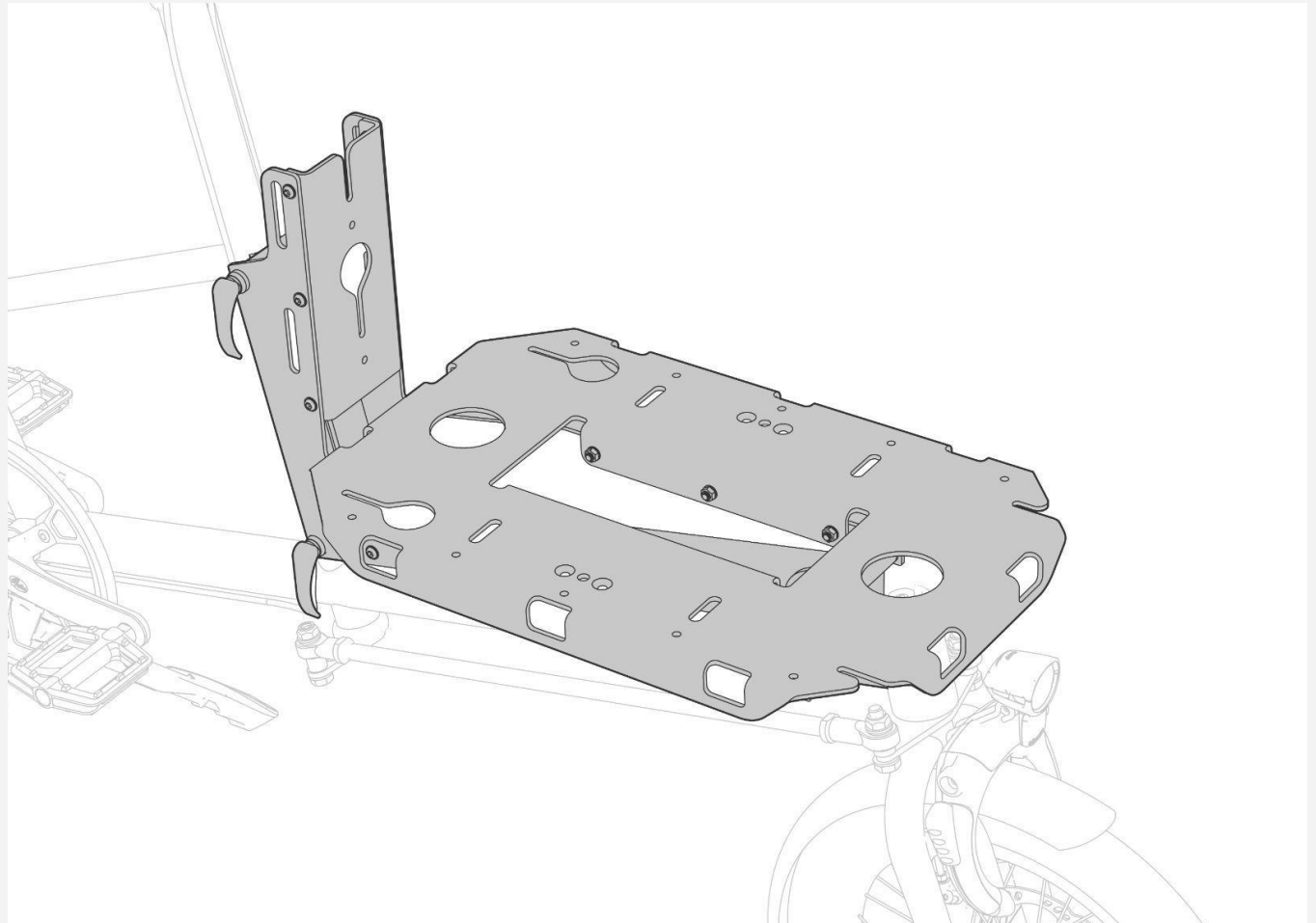

Use

When using the base carrier for transport, be careful when installing the attachment of your choice and carefully secure your load.



Insufficiently secured loads can result in accidents involving personal injury and property damage. Pay attention to your safety and that of your fellow human beings.

Assembling

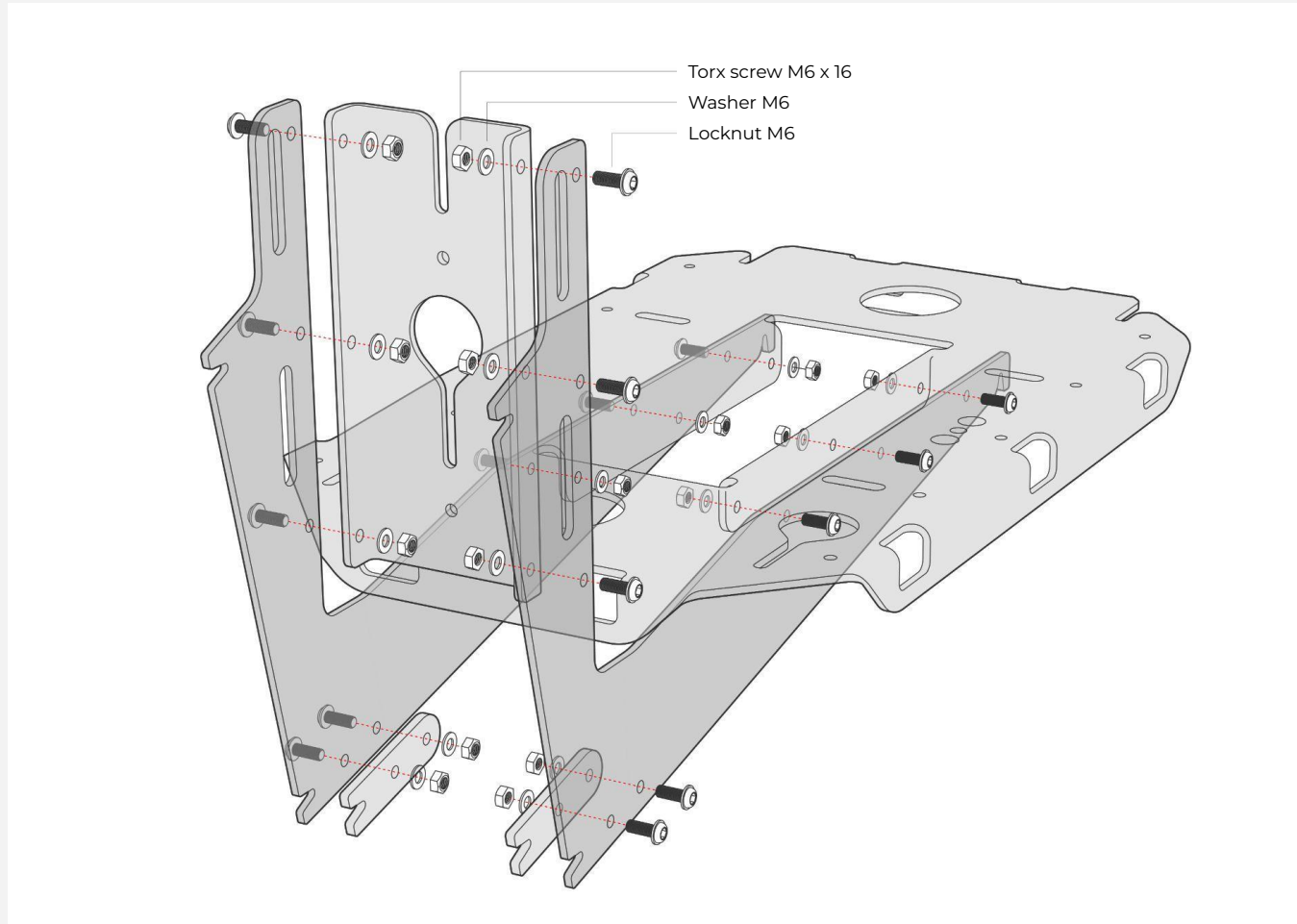

Step 1 Assembly of the individual parts

Assemble the carrier by screwing the aluminum sheets and profiles together using the small parts as shown in the illustration.

Mounting

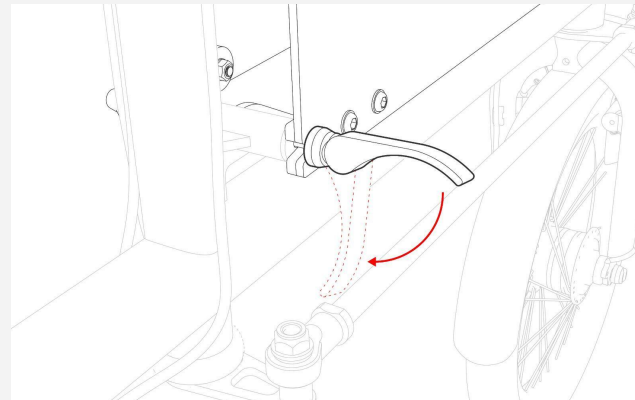
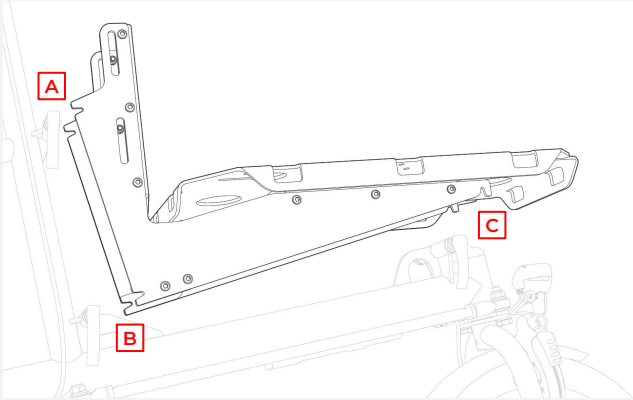

Step 2 Putting on the carrier

Place the dropout pairs on the quick release axles **[A, B, C]**.

Step 3 Tightening the levers

Now screw the quick releases tight and tighten the levers.
Make sure that the required clamping takes place at all three mounting points. The dropouts must sit firmly and without a gap between the mounting tube and the quick release.



When assembling your carrier, take your time and proceed carefully. If you are unsure about the assembly, let your service partner support you. It is important that the carrier is firmly connected to the Adapt system.



Before every ride, make sure that all pairs of dropouts are hooked onto the quick release axles and that the quick releases are tight. This is the only way to ensure that the carrier cannot come loose during the journey.

Euro Carrier

The YOONIT Euro Carrier offers a horizontal loading area of 80 x 60 cm, designed for Euro-sized boxes and other large-volume containers. Recesses in the loading area and in the surrounding strips allow the use of straps for attachment.

Components

- 1x Euro base plate
- 1x Euro rear plate
- 1x Euro side sheet right
- 1x Euro side sheet left
- 2x Euro Spacer sheet
- 2x Euro side rail
- 1x Euro front rail
- 4x Euro angle sheet

- 44x Stop nut SM/6
- 22x Countersunk screw M6x20
- 18x Flat headed screw M6x40
- 4x Flat headed screw M6x20
- 44x Washer M6
- 18x Spacer M6
- 2x Rubber bump stops
- 2x Anti-scratch strips

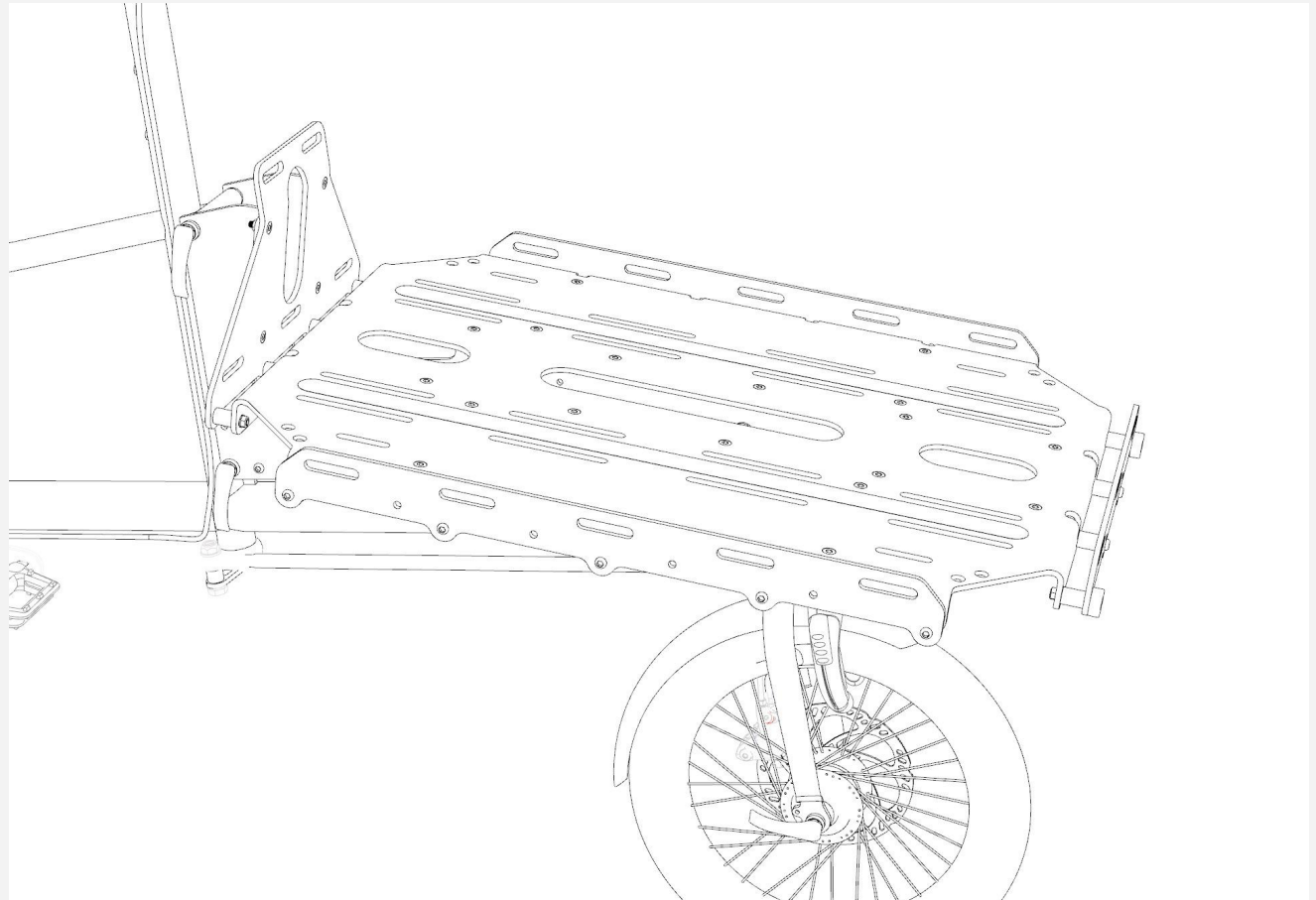

Use

When using the base carrier for transport, be careful when installing the attachment of your choice and carefully secure your load.



Insufficiently secured loads can result in accidents involving personal injury and property damage. Pay attention to your safety and that of your fellow human beings.

Assembling

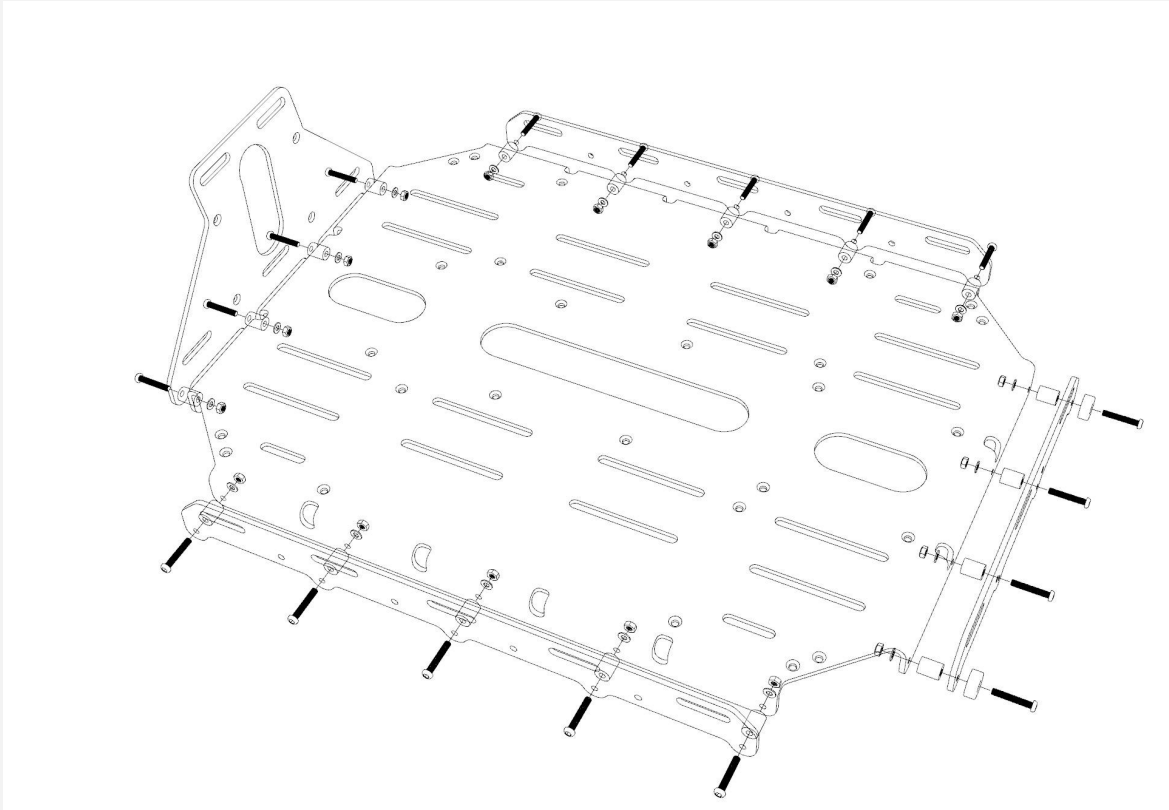

Step 1 Pre Assembly

Assemble the carrier by screwing the aluminum sheets and profiles together using the small parts. First mount the rear part as well as the side and front outer rails on the base plate. Pay attention to the orientation of the base plate, its two middle rows of holes are aligned to the front.

Small parts: 18x flat head screw M6x40, spacer, washer and stop nut

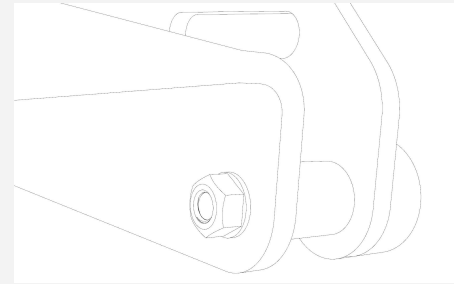

Tighten the screws for fastening the rubber buffers only that far that the screw ends remain just inside the nut and do not protrude.

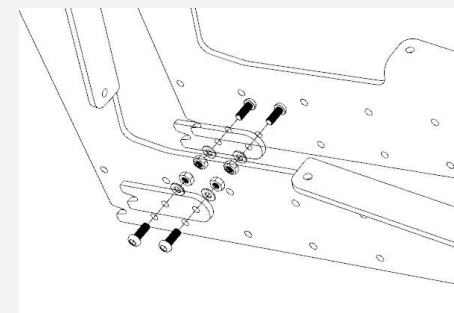
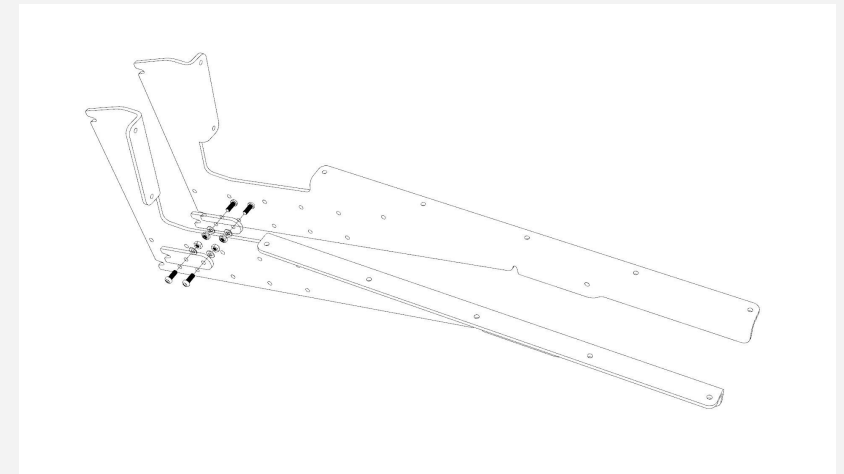

Step 2

Screw the spacer plates on the inside to the side parts.

Small parts: 4x flat head screw M6x20, washer and stop nut

Assembling

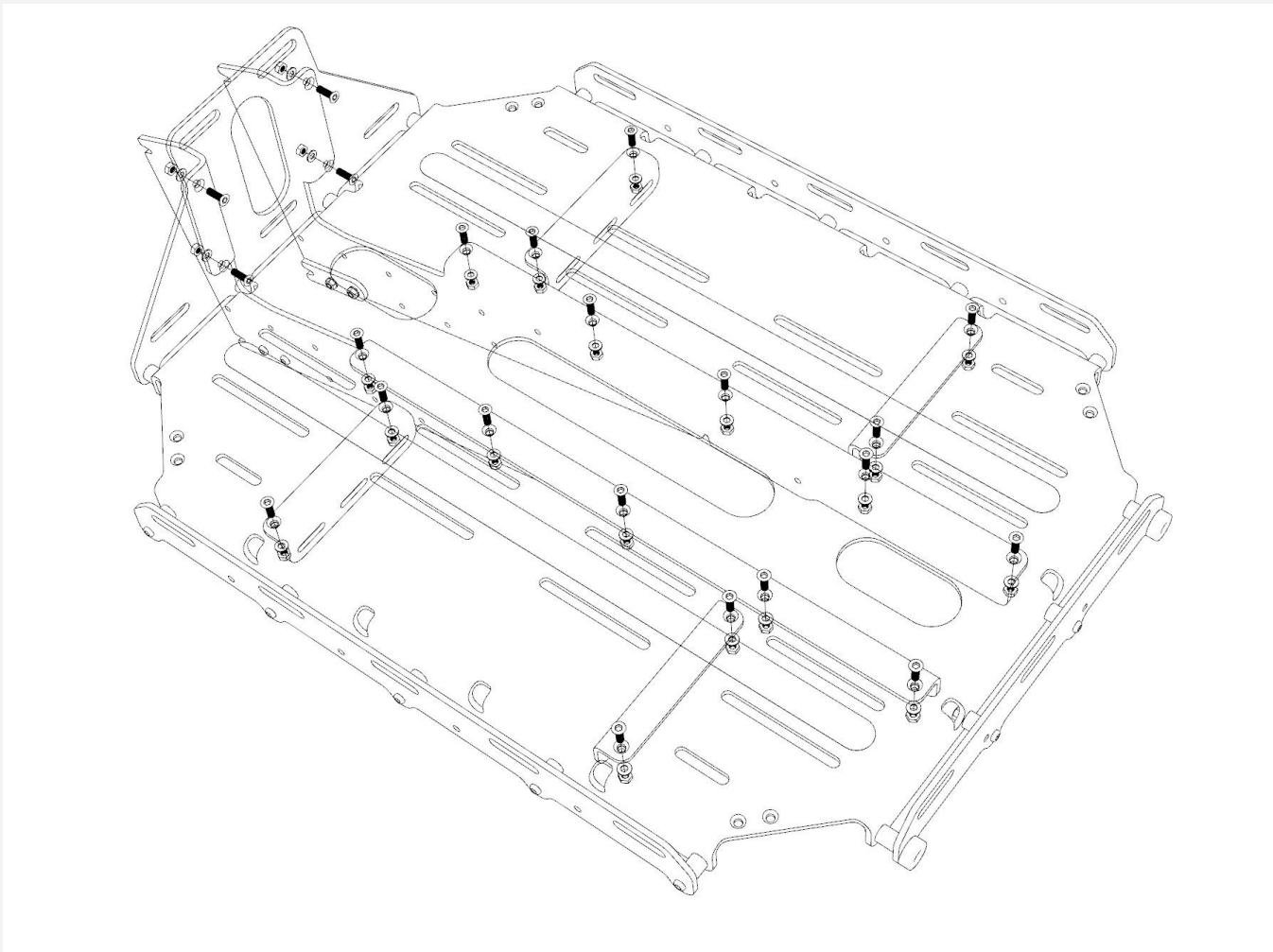

After the final assembly of all individual parts, it may be necessary to adjust the distance between the rear dropouts manually with a little effort.

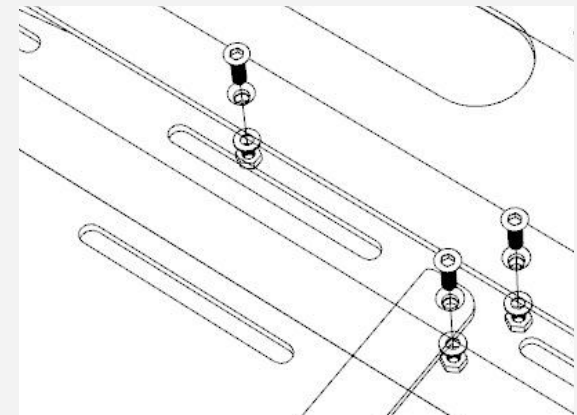

Step 3 Final Assembly

Bring the side parts and the angle sheets together with the back part and base plate. First tighten the screws and nuts hand-tight and only finally fix them when all parts are in position. **Small parts:** 22x Countersunk screw M6x20, spacer, washer and stop nut

Mounting

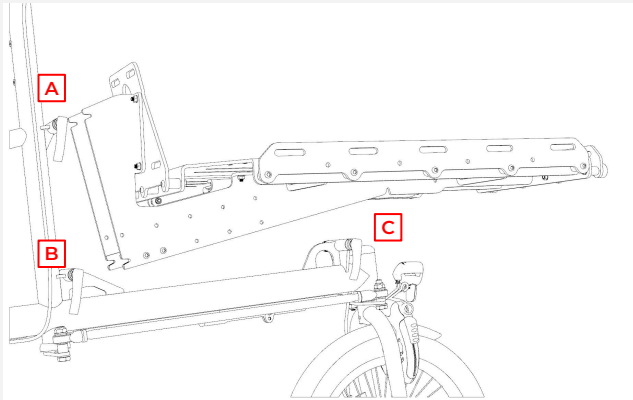

Step 4 Putting on the carrier

Place the dropout pairs on the quick release axles **[A, B, C]**.

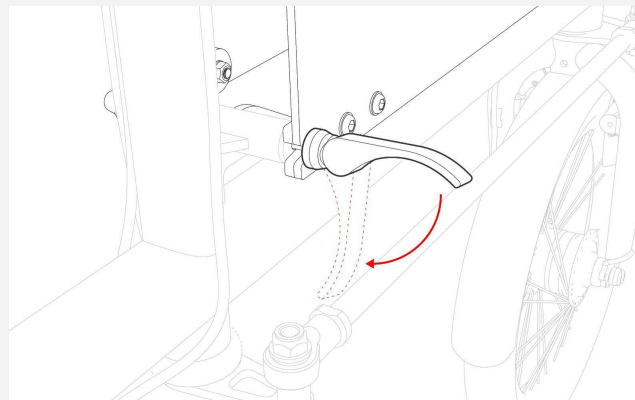

Step 5 Tightening the levers

Now screw the quick releases tight and tighten the levers.

Make sure that the required clamping takes place at all three mounting points. The dropouts must sit firmly and without a gap between the mounting tube and the quick release.



When assembling your carrier, take your time and proceed carefully. If you are unsure about the assembly, let your service partner support you. It is important that the carrier is firmly connected to the Adapt system.



Before every ride, make sure that all pairs of dropouts are hooked onto the quick release axles and that the quick releases are tight. This is the only way to ensure that the carrier cannot come loose during the journey.

YOONIT Rack

Your YOONIT can be equipped with the optionally available YOONIT rear rack. It is suitable for attaching standard bicycle bag systems.

Components

- 1x rack, powder coated black
- 1x adapter plate, powder coated black
- 1x replacement seat clamp
- 1x Z reflector
- small parts



The YOONIT rack has a maximum load of 20kg installed on the YOONIT. It is not permitted to transport children in a child seat attached to the rack.

Assembling

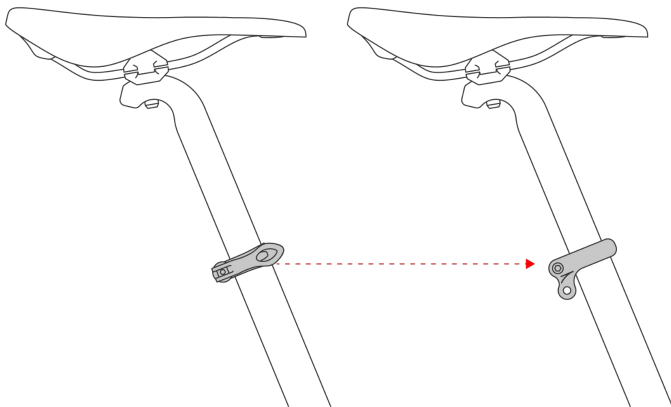

Step 1 Replacement of the seat clamp

First replace the standard seat clamp with the one included in the set.

Pay attention to the correct tightening torques.



Torx screw M5 x 12

Washer M5

Locknut M5

Torx screw M5 x 20

Washer M5

Cross-drive screw

Step 2 Pre-assembly

Loosely screw the adapter plate to the front of the rack frame using the appropriate screws and nuts **[A]**.

Attach the Z reflector **[B]** using the small parts from the set.

Step 3 Attaching the rack

Then mount the complete carrier on the replaced seat clamp **[C]** and the free threaded holes at the dropouts **[D]**.

Align it horizontally and now also tighten the screws on the adapter plate.

Spacer 10 mm
Washer M5
Allen screw M5 x 25

Weber Adapter

On your YOONIT you can optionally mount an adapter to attach the Weber ER hitch for attaching trailer drawbars. With this the range of applications can be expanded to include trailers for transporting children or loads.

Components

- 1x adapter plate, stainless steel, powder coated black [1]
- 2x screws M6 x 20 [2]
- 2x washer M8 (for attaching Weber ER hitch)
- 2x locknut M8 (for attaching Weber ER hitch)

Step 1 Preparation

Loosen and remove the two screws and washers on the left rear dropout.

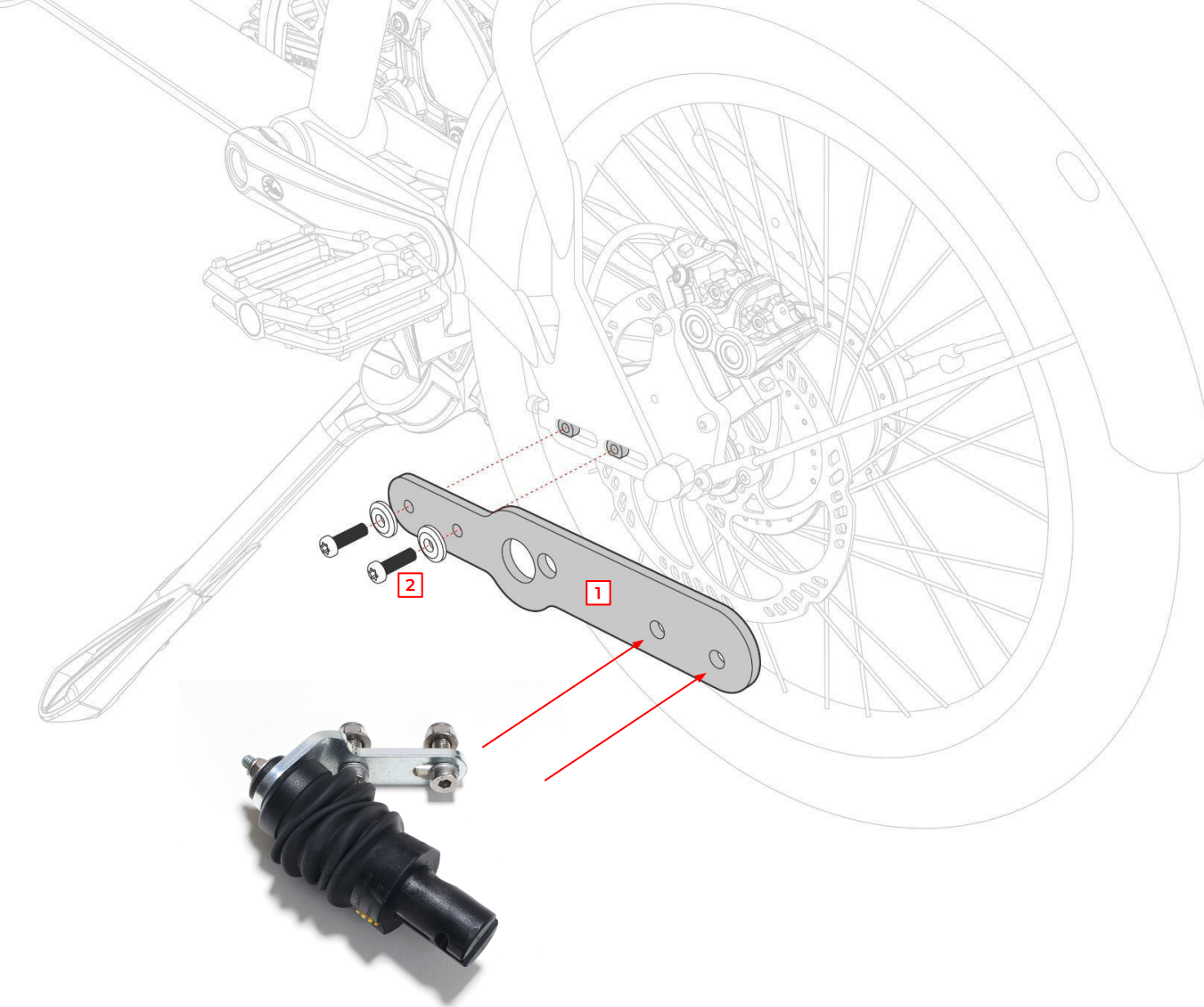

Step 2 Assembly

Place the Weber adapter according to its recesses and holes on the dropout and fasten it using the enclosed M6x20 replacement screws.

The adapter rests directly on the dropout, followed by the previously removed washers and replacement screws.



The adapter has a maximum trailer load of 80 kg corresponding to the weber ER hitch.



You can find more information about the Weber ER hitch at:

<https://www.weber-products.de/de/shop/produkt/ER-Kupplung-Kupplung-Fahrradanhaenger-Cargo-Kargo?product-id=387>

Steering

The indirect steering is transferred by a steering rod [1]. The adjustable steering damper [2] offers you additional driving comfort.

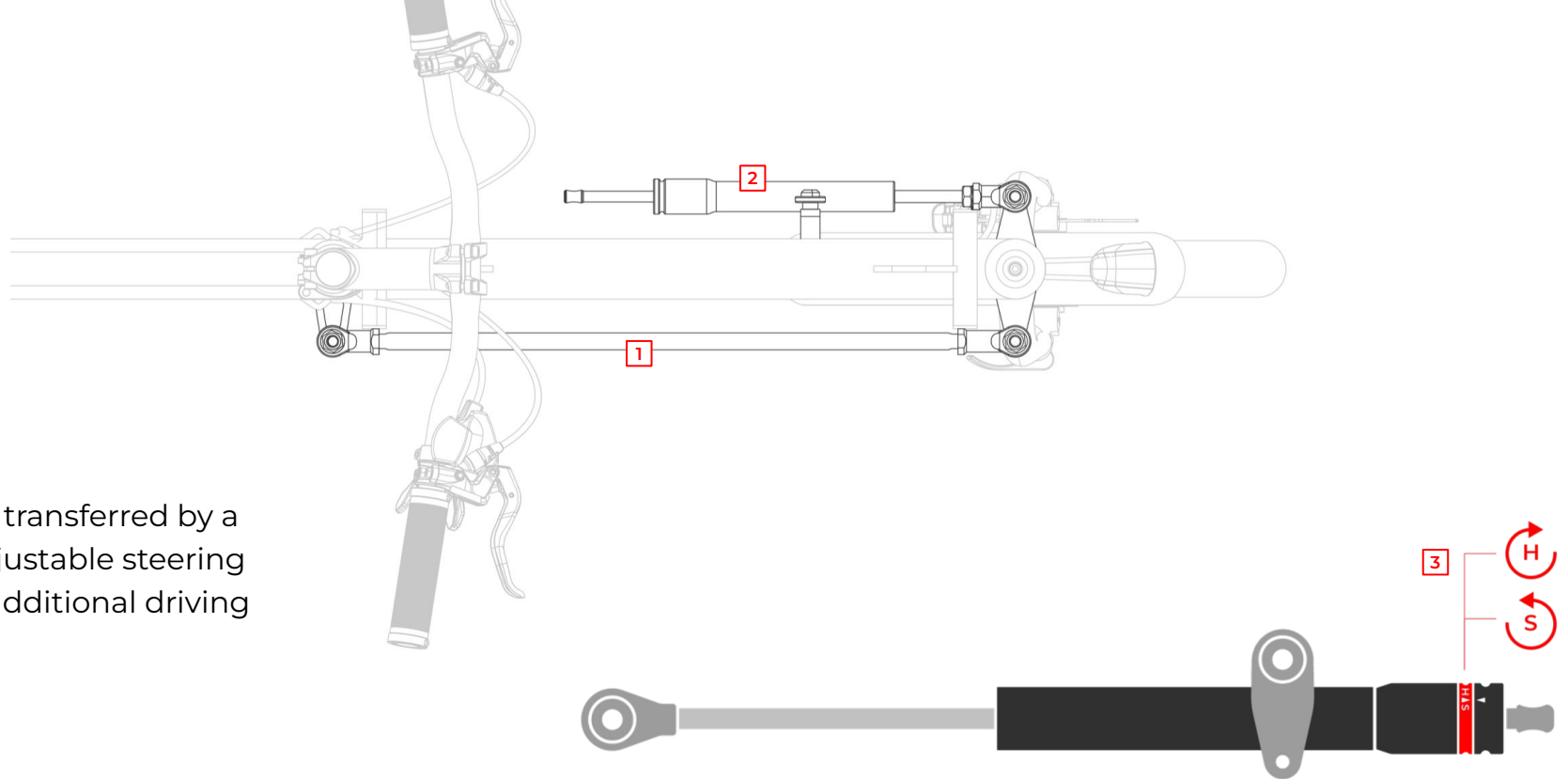

Despite its indirect steering, the YOONIT behaves similarly to a normal bicycle. Familiarize yourself with the steering in an undisturbed location.



The steering assembly is a complex system. Damage and changes can lead to serious falls. If you have any doubts about the stability/ function or discover defects in the parts, your YOONIT must no longer be used.

Do not attempt to repair defects in the steering assembly yourself or to replace parts. Contact a professional to do this.

Steering rod (control check)

Check the following things before driving:



- Check that the steering assembly runs without play.
- The steering must not be restricted in its movement.
- Check that the screws and nuts on the steering assembly are properly tightened.

Steering damper

Your YOONIT has an adjustable steering damper [2] as standard. You can set the intensity of the damping on the adjusting wheel [3] in nine stages. To increase the damping resistance, turn the adjustment wheel in the direction of "H", to decrease the resistance turn the adjustment wheel back in the direction of "S".

Brakes

Your YOONIT is equipped with two independent hydraulic disc brakes on the front and rear wheels. Check the function of the braking system regularly. Test the braking effect as well as the brake wear and check whether there are any leaks in the system. Replace the brake pads if they are dirty or if the thickness of the pads is less than one millimeter. The brake pads must not be braked so far that the carrier plate touches the brake disc.

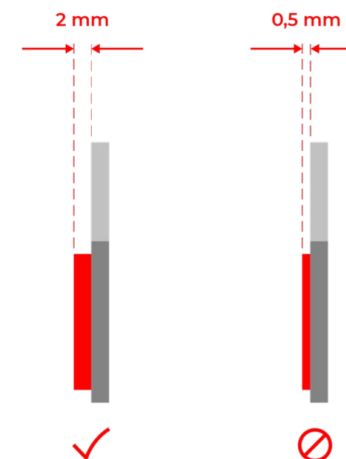
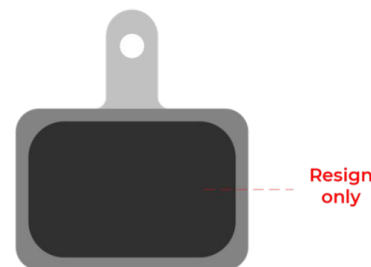

Running in

New brake discs and their brake pads must be run in. Only after running in does the full braking power develop.



Braking in: To do this, accelerate your YOONIT to 25 km/h and brake clearly to the stop. You should repeat this process about 20 times. Be aware that the brakes increase their braking force as you do this. Make sure that the wheels do not lock.



Disc brakes decelerate very quickly; pulling the brake lever vigorously can block the respective wheel and cause a fall.



Vapor Lock

Do not brake continuously over a long period of time, e.g. on a steep and long descent. Temporarily relieve the brake lever. The formation of vapor bubbles in the brake system suddenly increases the brake lever stroke considerably and can result in a total breakdown of the brake system. Such loss of control of the bike can cause serious falls.

Wear

The brake pads wear out after a certain period of time, so check the condition of the brake system and the brake pads regularly. Have your brake system serviced regularly by your YOONIT service partner. This concerns the check of the brake fluid, as well as the wear and tear of the pads. In order to brake properly, your brake discs must be clean and free of grease.



Have the thickness of the brake discs measured after three brake pad changes; brake discs can also wear out.

Brake levers

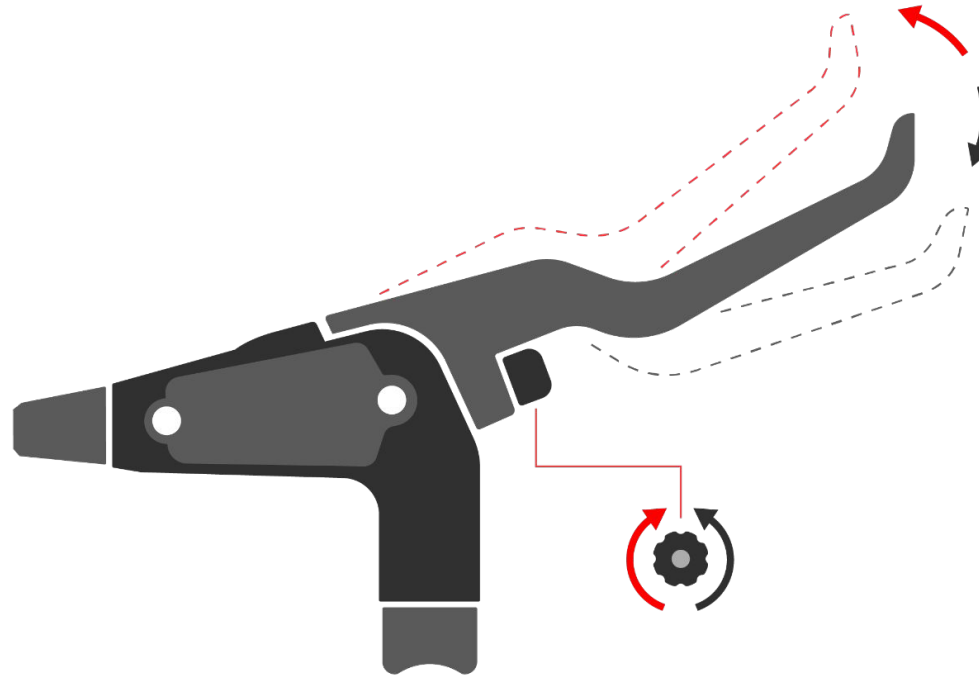

On your YOONIT, the brake lever on the left side of the handlebar acts on the front brake. The lever on the right acts on the rear brake.

It is possible to adapt the brake levers to the shape of your hand and to move them closer to the handlebars. To do this, turn the adjusting screw on the brake lever (see illustration). If you turn to the left, the lever comes closer to the handlebars. If you turn to the right, it moves further away. However, the levers should never touch the handlebars, even if they are pushed hard.



Adjust the brake levers so that they do not touch the handlebars even when pressed hard!



For more information about Magura hydraulic brakes, visit <https://www.magura.com/en/components/techcenter>

Gear shift



YOONIT Classic

The non-motorized version of the YOONIT is equipped with an Alfine 8-speed hub gear from Shimano. You shift gears using the shifter on the right-hand side of the handlebar, which is part of Shimano's Rapidfire shifting system.

If you want to shift into a higher gear, use the lever located on the side of the handlebars facing you and push the lever forward with your thumb. You can downshift into a lower gear by pulling the lever on the opposite side of the handlebars towards you with your index finger.

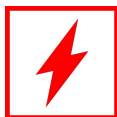

YOONIT Electric

The pedelec version YOONIT Electric shifts with the automatic 5-speed hub gear SHIMANO STEPS Di2. The control unit is located on the right side of the cockpit. Two automatic and one manual mode are available, which you can change using the middle button. Gear 2 is always selected at the start.

You can increase the gear with the upper button and decrease it with the lower button. In automatic mode, the system shifts automatically. Since it is an adaptive system, you have the option of changing gears manually or correcting them at any time. Over time, the system will adapt to your driving style.

With the two automatic modes, the system can learn the shifting behaviour of two drivers.



The gear shift is one of the components that are relevant to your safety. Please read through the enclosed instructions from the manufacturer and familiarize yourself with how it works before you set off.

If you have any questions about setting and operation, you can contact the YOONIT team at any time: hello@yoonitbikes.com. Alternatively, your specialist dealer can also help you.

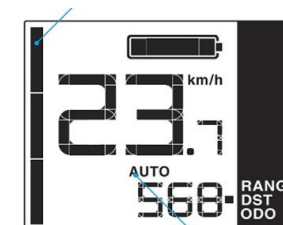

Auto gear shifting display
Displayed for the auto gear shifting.

Gates belt drive

The Gates Carbon Drive is a maintenance-free and durable system. Note the following points before your ride.

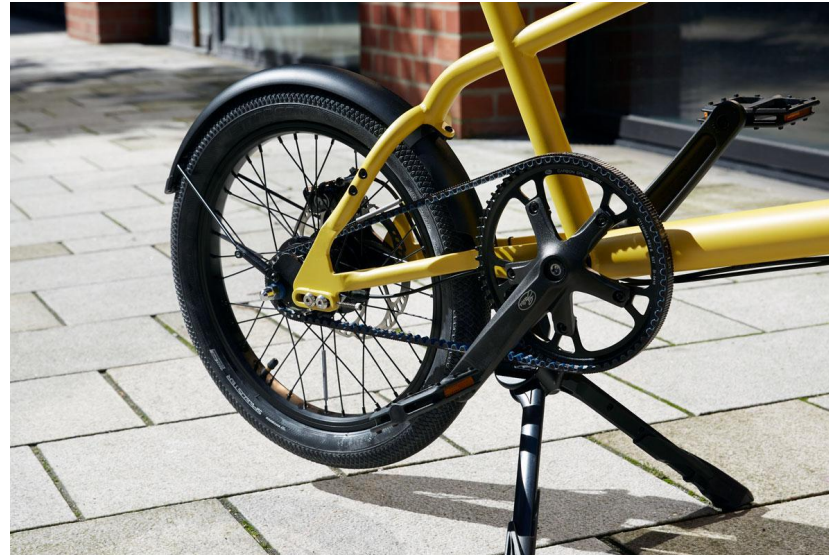

After driving through mud or dirt, clean the belt with water or a hand broom. This will prevent premature wear and tear or noise such as squeaking or creaking.

When cleaning the belt, watch out for any damage, cracks, or deformations in the material.

Check the belt tension and pulleys regularly. If you notice changes, contact your service partner.



Loose clothing can get caught in the belt drive and block it. Attention! This can lead to dangerous situations. When cleaning, be careful not to pinch your fingers between the belt and pulley.

Wheels and tires

The wheels of your YOONIT are exposed to heavy loads. Your service partner should check it after 100 km to 300 km and readjust it if necessary. Also check the wheels yourself regularly.

Tires and air pressure

The appropriate air pressure for the tires is either specified in bar and PSI on the side of the tire or on a label on the rim. Please always ride with a suitable air pressure that suits the driver and the load.



Air pressure front wheel:

2,8 bar (40 psi) bis 4,6 bar (65 psi)

Air pressure rear wheel:

2,8 bar (40 psi) bis 4,6 bar (65 psi)

Hub bearing

Check the hub bearing from time to time by lifting the wheel off the ground and turning it by hand. If the bike does not run regularly or stops suddenly, this is a sign of a defective bearing.

There must be no play in the hub bearing. Check this regularly by pulling the front wheel in the fork or the rear wheel in the rear triangle to the right and left. It can't be loose or have play. If you find play, have the bearings adjusted by a service partner.

Rim concentricity

The runout of the rim must also be checked from time to time. Lift the impeller off the floor and spin it by hand. On the rim flank you can see whether the rim is deflecting to the side or whether it is running straight. Unless it is currently running, your service partner should center the rim.

Fixing a flat tire

Contact a specialist workshop if you have a flat tire. Expertise and special tools are required for repairs.

Lighting system

The YOONIT is equipped with a front and rear light from Busch und Müller. The rear light is integrated in the rear fender.



A functioning lighting system is mandatory in order to participate in road traffic. Without them, participation is prohibited. You cannot see the road properly and other road users cannot see you and your passengers. There is a risk of accident!

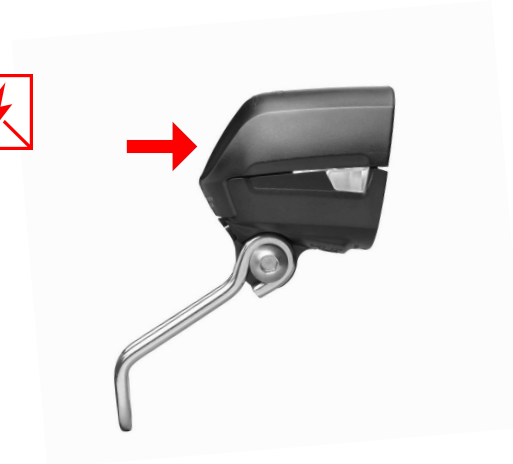

YOONIT Classic

The lighting system of the YOONIT Classic is supplied with alternating current (AC) via the hub dynamo. In order to switch the headlights on or off, press the large toggle switch on the back of the front headlight.



YOONIT Electric

The lighting system of the YOONIT Electric is powered by direct current (DC) from the STEPS battery. You can switch the lighting on/off via the lower button on the bike computer.

Adjusting the headlight

The headlight must not dazzle other road users. According to the StVZO, the light cone must be inclined so that its center is only half as high at a distance of 5 meters as when it exited the headlight. Therefore set it as shown on the sketch.

You should clean the reflectors and headlights regularly to ensure that they function properly. Warm water and detergent work well for this.

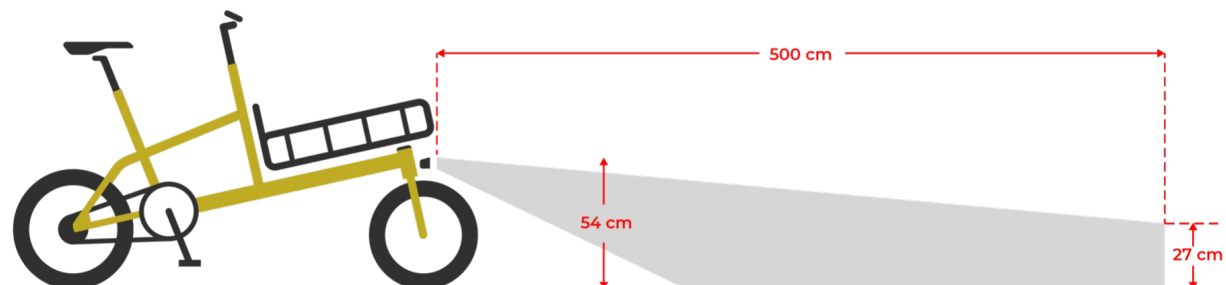

Lighting system

YOONIT Classic

The YOONIT is equipped with a front and rear headlight from Busch and Müller, which are supplied with alternating current (AC) by the hub dynamo. The rear light is built into the rear fender.

To turn the headlights on or off, press the large toggle switch on the back of the headlight.

YOONIT Electric

The lighting system of the YOONIT Electric is fed with direct current (DC) from the STEPS battery. Your YOONIT Electric is delivered ex works with permanent light. If you switch on your e-bike system, the front and rear lights light up. We recommend keeping this basic setting.

If you still want to switch off the lighting system, you can do this via the menu in the display. To do this, press the function key at the bottom left of the display and use the control unit to select the "Light" menu item.



A functioning lighting system is mandatory in order to participate in road traffic. Without them, participation is prohibited. You cannot see the road properly and other road users cannot see you and your passengers. There is a risk of accident!

Adjusting the headlight

The headlight must not dazzle other road users. According to the StVZO, the light cone must be inclined so that its center is only half as high at a distance of 5 meters as when it exited the headlight. Therefore set it as shown on the sketch.

You should clean the reflectors and headlights regularly to ensure that they function properly. Warm water and detergent work well for this.

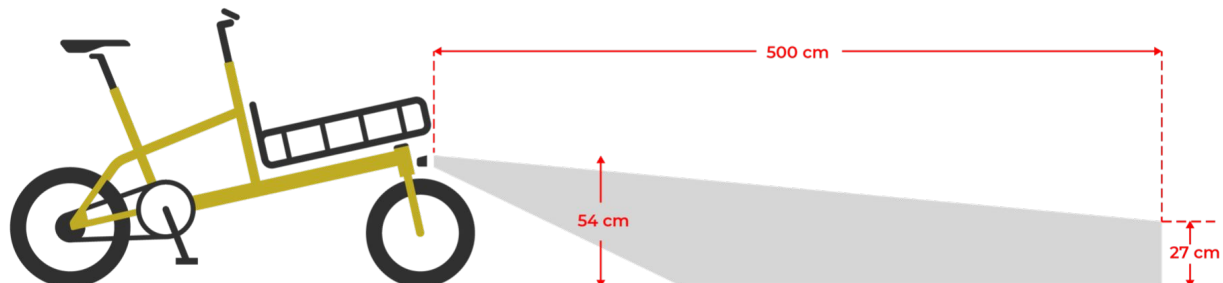

Double kickstand

Your YOONIT stands on a stable double foot stand with a maximum load of 80 kg.

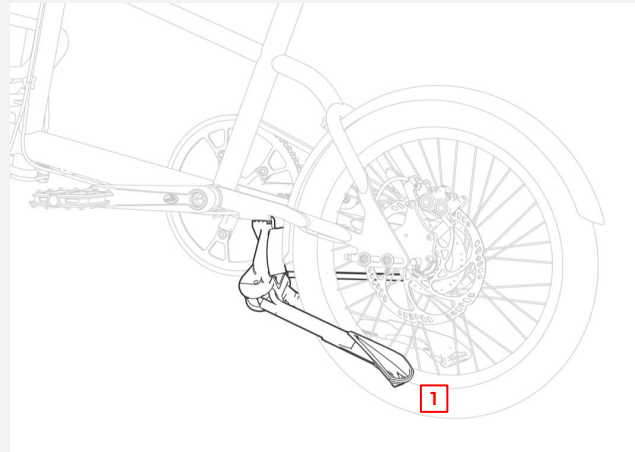

To unfold the stand to park the YOONIT, place your foot behind one of the stand legs **[1]**. Push the YOONIT back so that the stand unfolds against your foot. Lift the YOONIT slightly by the saddle to make the process easier.

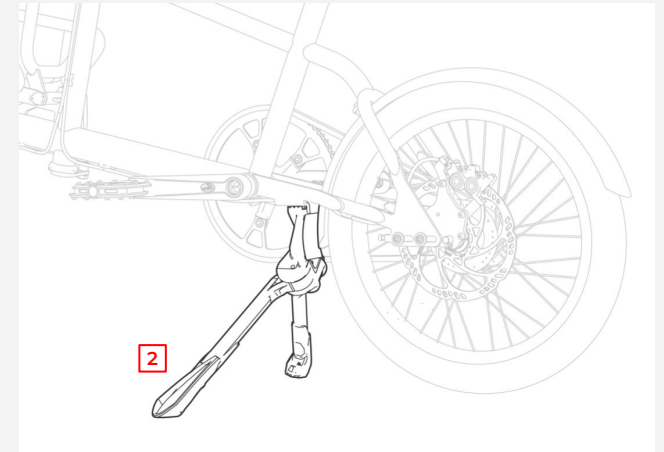

Do the reverse to raise the stand to continue your journey. Place your foot in front of the stand **[2]**, lift the YOONIT a little and push it forward so that the stand legs fold against your foot.



Be careful not to kick the rear brake disc if you want to open the stand to park the bike.



Do not sit on your YOONIT when the kickstand is unfolded. This could be damaged by the load.

Frame lock

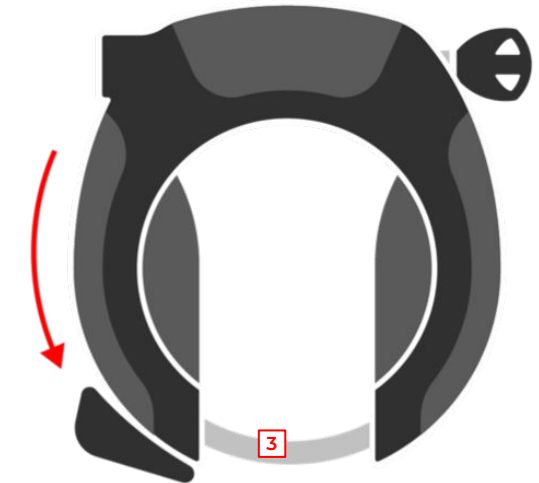

Your YOONIT can be secured against theft with the frame lock built into the front fork. The lock is suitable for the use of different adapter chains.

Turn the key [1] and push the tension bolt [2] down to close the lock. Make sure that the spokes are not damaged when you close the locking bracket [3]. If there are spokes in the way of the bracket, turn the front wheel a little.

The locking pin [4] of an adapter chain can be easily inserted into the opening of the ring lock, even if there is no key in the lock. To open, turn the key - the bolt releases the chain.

The key can be removed when the bolt is closed or when the lock is open.



Before every ride, check that your frame lock is open. If you start against the locked bolt, you could seriously damage the wheel!



When using an adapter chain, guide it through the eyelet provided on the frame at the front of the YOONIT's down tube to secure the front wheel and frame. The length of the chain is also sufficient to connect your carrier.

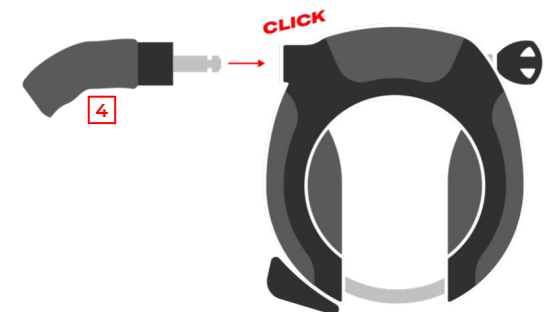

Bottle holder

You can mount a standard bottle holder on the handlebar [1] of your YOONIT. When assembling, make sure that you use the screws for fastening that are already built into the YOONIT mounts.

It is very important that the fastening screws do not dip too deeply and block the steering shaft [2] in the steering tube!

First determine the material thickness at the mounting points of your bottle cage. The distance from the bottom [4] of the screw head to the handlebar must be at least 3-4 mm. You can achieve this distance with the washers [3].

Contact your service partner if you are not sure about the installation.

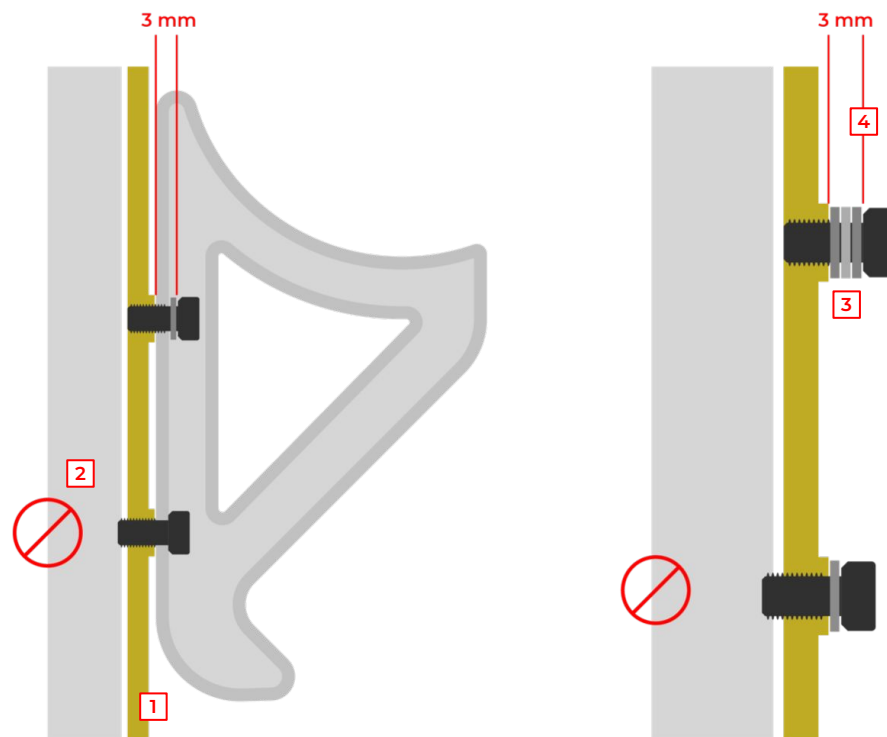

The screws of the bottle holder must never block the steering shaft [2]. The steering becomes unusable and you risk an accident.

Frame

In these operating instructions you will find a service book for your YOONIT. If your YOONIT is stolen, it can be identified by its frame number. You can enter the frame number in the service book.



Do not ride with a defective frame! Deformations or cracks impair the safety and function. This can only be remedied by having the damaged parts replaced by a specialist workshop. Damage to the frame or components can lead to accidents! You can recognize a warped frame or a defective fork by means of improper straight-line stability. In this case, be sure to contact your service partner to have these components checked.

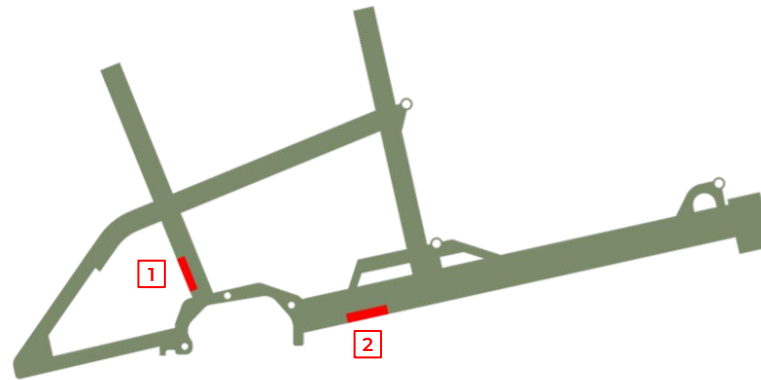
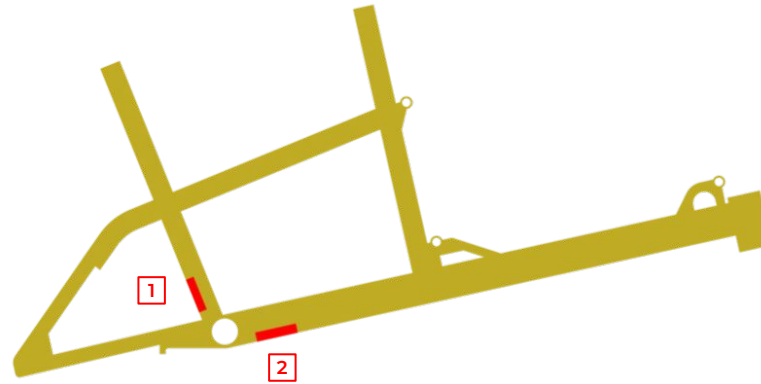

1

You can find the nameplate of your YOONIT here

2

The serial number of your YOONIT you can find here

Starting the e-bike system

Your YOONIT Electric is powered by the Shimano STEPS EP6 system.

Here we give you an overview of its functions and operation.

Step 1 Note the following things to be able to start and use the system of your YOONIT Electric:

- Is the battery charged sufficiently?
- Is the battery properly seated in its holder?
- Are the battery, motor and control unit correctly connected to each other?



Step 2 Switching the STEPS system on and off

To start the system, press the upper button on the cycle computer until the display lights up. Proceed in the same way to switch off.

STEPS control unit

You can find the control unit of your YOONIT Electric on the cockpit, it consists of the STEPS display [1] (right in the middle of the handlebar) and the STEPS support switch [2] (on the left handlebar side).



To operate the on-board computer and its setting options, please refer to the manufacturer's operating instructions. You can find more information at si.shimano.com

Step 3 Choose your support mode

You can choose between three modes using the assistance switch on the left side of the handlebar:

ECO — the lowest support level (49 Nm) is designed for the most efficient possible driving style in order to maximize your range.

TRAIL — Dynamically uses the entire 85 Nm of the EP6 drive. Motor assistance is provided depending on how hard you pedal. The drive unit adapts quickly and independently to your driving style.

BOOST — Provides the strongest support. For the EP6 drive unit, this means maximum and permanent 85 Nm torque and 400% additional pedaling support.

Battery

The BT-E8016 battery developed for the Shimano STEPS system is attached to the down tube and offers optimal handling thanks to its low center of gravity. You can cover great distances with it and it offers a quick charge function.

Control check

- Is the battery securely locked in the holder?
- Make sure that the battery does not discharge completely. You can recharge it even after using it for a short time. If the device is not used for a long time, the charging capacity may decrease.
- The battery should only be charged for as long as the manufacturer specifies.
- Unplug charger and battery when they are fully charged.
- Do not drive with the key inserted.
- Make sure the charging port cap is closed.

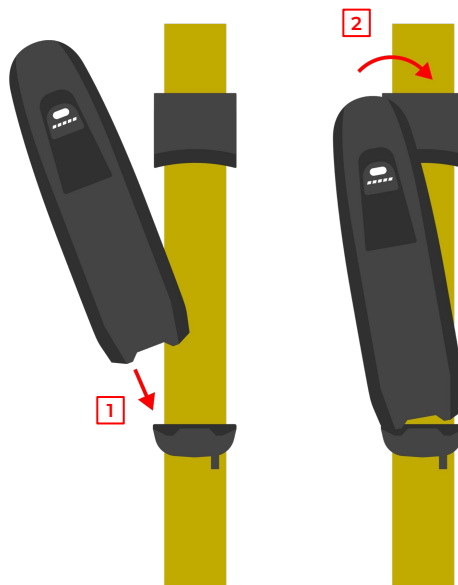

Inserting the battery

Insert the back of the battery onto the plastic tab **[1]** on the rear battery holder. Once the battery is hooked into the tab, turn it towards the front battery holder **[2]**. So you push it from the left onto the front bracket until it clicks into place.

The key is not required for insertion. The battery is secured as soon as it is engaged.



Hold the battery firmly and do not drop it, otherwise it could be damaged permanently.

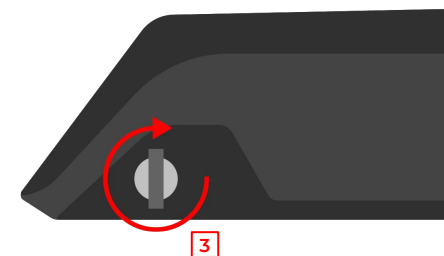

Removing the battery

To remove the battery, turn the key in the battery lock clockwise **[3]** so that the lock is open. You can now remove the battery by carefully sliding it from the holder counterclockwise.



You can find out more about using your STEPS battery at si.shimano.com.

Charging the battery

Charge the battery by plugging the charging cable of the supplied charger into the charging socket. To do this, the battery can be removed from the YOONIT, or it can be charged when mounted on the bike. **You can find detailed manufacturer information at si.shimano.com.**

If the system is switched on, you can read the charge status of the battery from the charge status lamps. Even when the system is switched off or the battery is removed, you can display the charge by pressing the button on the battery.





State of charge	Indication
100 % — 81 %	
80 % — 61 %	
60 % — 41 %	
40 % — 21 %	
20 % — 1 %	
0 %	

 Make a note of the key number of the battery lock in your service book, you can find it as an embossing on the back of the key bit. If you lose the key, you can request a replacement key from your service partner by quoting the number.

 The battery draws attention to possible malfunctions by means of light and flashing patterns. You can find information on this in the instructions supplied.

 Please observe the manufacturer's operating and warning instructions (si.shimano.com) in order to avoid possible dangerous situations. The label on the charger supplied also contains important information on use.

 Before you charge the battery, refer to the enclosed instructions for the electric drive to find out about the safety-related information on battery and system. There is a risk of electric shock if handled improperly! Always use original parts from the manufacturer and adhere to their safety information.

 Never open the battery or charger; this could result in a short circuit and/ or electric shock! You will then lose your guarantee. Protect the battery from mechanical damage, heat (direct and prolonged sunlight), fire and immersion in water. There is a risk of explosion! Keep children away from the battery. Damage and improper use may cause toxic fumes to escape.

 If your battery is defective, do not use or charge it anymore. Do not cover the charger during operation, there is a risk of a short circuit or fire!

Safety instructions for battery and charging



As part of the inspection, the electric drive should be checked by a service partner to ensure that it is working properly. If the electrical system has been damaged, remove the battery immediately to avoid further damage. Do not hesitate to contact your service partner or us if you have any questions or problems with the electrical system.



Always remove the battery when you want to transport it or carry out maintenance and repair work. You could inadvertently activate the electrical system, which can lead to injury.

Range

The range is influenced by the outside temperature, your driving style and the terrain in which you move. The battery lasts the longest in warm temperatures and with low support.

Physical processes at low temperatures reduce the range of your YOONIT. This is a normal characteristic and not a fault in your battery. The battery stores and outputs the full energy at warmer temperatures. Keep this in mind when planning and when driving in cool temperatures. Adjust the support level if necessary.



In cool outside temperatures, we recommend that you do not leave the battery on the bike, but rather store it at room temperature. If you insert the battery directly before starting your journey, it will hardly lose any energy and will warm itself up during the journey. This helps to increase your reach.

Wear

The life of the battery depends on various factors:

- the number of charging cycles
- the age of the battery
- the conditions during use

Even if you do not use your battery or use it little, its capacity will decrease over time. Your service partner can use the remote diagnosis from Shimano to read the status of your battery and the number of charging cycles.

You can find information on maintenance at Shimano at [si.shimano.com](https://www.shimano.com)



The service life of the battery is influenced by the type of use and the number of charging cycles. This affects the range that you can cover with your YOONIT. This is a normal process and does not represent a fault. If the range has been greatly reduced despite a charged battery, its service life has been exceeded. Exchange it for an original part from Shimano.

Care and cleaning

To enjoy your YOONIT for a long time, regular maintenance and care is important. Follow these tips to gently clean your YOONIT. If you need any further assistance, please contact us at: **hello@yoonitbikes.com**

Cleaning with clear water is ideal for your YOONIT. The frame can be polished well with a microfiber cloth.

Clean the seat with a damp cloth, more stubborn dirt can be removed with a soap-free cleaner. Do not use harsh detergents.

Only clean the Gates Carbon Drive with water. Unlike a chain, the belt does not need to be greased.

If necessary, you can wipe the contacts of the battery with a damp cloth. However, be sure to wait until you put the battery back in, as the contacts must be dry.



Before doing any work on your YOONIT such as maintenance or care, please remove the battery. Inadvertent activation of the electrical system can result in injury.



Cleaning with a high-pressure device can damage the electrical system. Due to the high pressure, cleaning fluid can also get into sealed parts and damage them.



Oil that gets on the brake discs or pads will degrade the braking effect. Prevent oil from coming into contact with brake discs or pads!

Inspection

Your YOONIT is a mechanical device and in everyday use it is exposed to high loads that result in wear and tear. For your safety and the lifespan of your bike, you should follow our instructions for regular inspections. Your service partner is the first point of contact for this. You will also find the service booklet in the scope of delivery, in which you can have the required service work entered.

Please note the maintenance and repair intervals that you will find in these operating instructions. They are part of the intended use. Your warranty on the YOONIT expires if the intended use is not adhered to.

Transport



Air

The battery must be transported as dangerous goods and specially marked. Find out more from the airline. You should find out about the regulations for transporting bicycles/ e-cargo bikes on board an aircraft in advance.

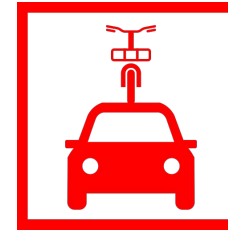

Road

With enough cargo space or a suitable bike rack, you can take your YOONIT with you in the car. Do not transport the battery installed on the bike, but separately. If you are transporting it on a bike rack, attach the YOONIT securely.

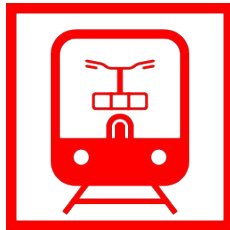

Rails

Most of the time, the same rules apply as when transporting a normal bicycle. We recommend transporting the battery separately during the entire journey. In local public transport there are different regulations regarding the transport or taking of cargo bikes. Simply find out more from the route operator beforehand. In any case, you have the option of quickly removing your carrier and using the holding devices for normal bikes.

Tightening torques for screws

Your YOONIT was assembled with great care and the screws tightened with the appropriate torques. It can happen that individual screws lose their pre-tensioning force due to setting processes and therefore have to be retightened. Your dealer will do this for you as part of the initial inspection. Screws must be loosened and tightened again during maintenance or adjustment processes. The tightening torques given in the table must also be observed here.

Type of component	YOONIT Classic	YOONIT Electric
Rear hub axle bolts	35-40 Nm	35-40 Nm
Adjustable dropouts	13 Nm	13 Nm
Frame opening	13 Nm	13 Nm
Square bottom bracket (Thun Jive)	30 Nm	—
Spider Lockring	—	35-45 Nm
Crank mounting screws	47-54 Nm	12 Nm
Chainring bolts	12-16 Nm	12-16 Nm
Pedals	35-40 Nm	35-40 Nm
Engine suspension	—	10-12,5 Nm
Handlebar clamp stem	6-8 Nm	6-8 Nm
Ahead stem clamping head tube	6-8 Nm	6-8 Nm
Stem adapter	6-8 Nm	6-8 Nm
Counter nut steering rod joint head	16 Nm	16 Nm
Steering rod attachment	16 Nm	16 Nm
Steering damper fastening screw	16 Nm	16 Nm
Brake lever	3 Nm	3 Nm
Caliper and adapter	6-8 Nm	6-8 Nm
Lockring brake disc	40 Nm	40 Nm
Saddle attachment	8 Nm	8 Nm

Warranty and guarantee

Liability for defects

Your bike has been manufactured with great care and will largely be handed over to you pre-assembled. In order to guarantee the intended durability and service life, the bicycle must only be used for its intended purpose. According to the law, we undertake to deliver bicycles that are not defective, so that their value and suitability are not impaired.

During the first 2 years after purchase, you are entitled to the statutory warranty. For this purpose, keep the proof of purchase and the documents carefully.

The instructions for assembly (e.g. torque of the screws) and the described inspection in the prescribed maintenance intervals must be observed.

We wish you a good trip and lots of fun with your YOONIT. If you have any questions, we are there for you: +49 40 53027341 and hello@yoonitbikes.com

After the last trip

Your YOONIT was designed in such a way that you can enjoy it for as long as possible. With good care, it can be with you for many years. At some point, however, the time will come when a repair is no longer possible or no longer makes economic or ecological sense. Then your YOONIT must be shut down and properly disposed of. Only in this way can the materials used be fed back into the material cycle, from which new things can arise.

Disposal of the battery

Batteries that are no longer usable must be collected separately in accordance with European Directive 2006 & 66/ EC and recycled in an environmentally friendly manner. Your specialist dealer will help you dispose of your battery.



Never dispose of your used battery in the normal household waste!



As a rule, you are not allowed to send the battery as a parcel! If in doubt, ask your shipping service provider for more information.

Frame and bicycle components

Electrical and electronic equipment that can no longer be used must be recycled in an environmentally friendly manner, in accordance with EU Directive 2012/19/EU. This includes the electronic components, the drive unit of your YOONIT Electric and also the battery charger. In Germany, you can return your YOONIT to municipal collection points for professional disposal at the end of its service life.

Imprint

Publisher

YOONIT bikes

— a brand of uuio GmbH

Langenfelder Straße 93
22769 Hamburg
Germany

+49 40 53027341
hello@yoonitbikes.com
yoonitbikes.com

Image rights

uuio GmbH
Shimano

Illustrations

uuio GmbH

Concept and design

uuio GmbH

Status: October 2023

© Duplication, reprinting and translation as well as any commercial use (including extracts, in printed or electronic form) are only permitted with prior written approval.

The operating instructions for your YOONIT can only be accessed digitally. This makes ecological sense and we can guarantee that it can be constantly updated and that you are always up to date.

Of course, you can also print it out yourself. But please pay attention to whether it is absolutely necessary.

These operating instructions cover the requirements and scope of DIN EN 79010: 2020-02 and DIN EN 15194: 2018-11.

For delivery and use outside of these areas, the manufacturer of the vehicle must include the necessary instructions.